

# OPERATION AND MAINTENANCE INSTRUCTIONS



## Self-propelled scissor platform COMPACT 8, 10, 12 DX



2420316890 - E 11.01



# Pinguely - Haulotte



La Péronnière - BP 9 - 42152 L'HORME - FRANCE

☎ 00 33 (0)4 77 29 24 24 - Fax 00 33 (0)4 77 31 28 11

E-Mail: Haulotte @ haulotte.com - Http: \\www.haulotte.com



---

## GENERAL

---

You have just taken delivery of your mobile elevating work platform

It will give you complete satisfaction if you follow the operating and maintenance instructions exactly.

The purpose of this instruction manual is to help you in this.

We stress the importance:

- of complying with the safety instructions relating to the machine itself, its use and its environment,
- of using it within the limits of its performances,
- of proper maintenance upon which its service life depends.

During and beyond the warranty period, our After-Sales Department is at your disposal for any service you might need.

Contact in this case our Local Agent or our Factory After-Sales Department, specifying the exact type of machine and its serial number.

When ordering consumables or spares, use this documentation, together with the "Spares" catalogue so as to receive original parts, the only guarantee of interchangeability and perfect operation.



**Caution !**

***This manual is supplied with the machine and is included on the delivery note.***

---

---

REMINDER: You are reminded that our machines comply with the provisions of the "Machines Directive" 89/392/EEC of June 14th 1989 as amended by the directives 91/368/EEC of June 21st 1991, 93/44/EEC of June 14th 1993, 93/68/EEC of July 22nd 1993 and 89/336/EEC of May 3rd 1989.

---



**Caution !**

***The technical data contained in this manual cannot involve our responsibility and we reserve the right to proceed with improvements or modifications without amending this manual.***

---



---

## CONTENTS

---

<b>1 - GENERAL RECOMMENDATIONS - SAFETY .....</b>	<b>1</b>
1.1 - GENERAL WARNING .....	1
1.1.1 - Manual .....	1
1.1.2 - Labels .....	1
1.1.3 - Safety.....	1
1.2 - GENERAL SAFETY INSTRUCTIONS.....	2
1.2.1 - Operators .....	2
1.2.2 - Environment.....	2
1.2.3 - Using the machine .....	2
1.3 - RESIDUAL RISKS .....	4
1.3.1 - Risks of jolting - Overturning.....	4
1.3.2 - Electrical risks .....	4
1.3.3 - Risks of explosion or burning.....	4
1.3.4 - Risks of collision .....	4
1.4 - VERIFICATIONS .....	4
1.4.1 - Routine verifications.....	4
1.4.2 - Examination of suitability of a machine.....	5
1.4.3 - State of conservation .....	5
1.5 - REPAIRS AND ADJUSTMENTS.....	5
1.6 - VERIFICATIONS AT THE TIME OF PUTTING BACK INTO SERVICE.....	5
<b>2 - PRESENTATION .....</b>	<b>7</b>
2.1 - IDENTIFICATION .....	7
2.2 - MAIN COMPONENTS .....	8
2.3 - DESCRIPTION .....	8
2.4 - WORKING AREA .....	10
2.4.1 - Compact 8 DX.....	10
2.4.2 - Compact 10DX.....	11
2.4.3 - Compact 12DX.....	12

---

2.5 -	SIZE .....	13
2.5.1 -	COMPACT 8DX size .....	13
2.5.2 -	COMPACT 10DX size .....	14
2.5.3 -	COMPACT 12DX size .....	14
2.6 -	TECHNICAL DATA .....	15
2.6.1 -	COMPACT 8 DX technical data .....	15
2.6.2 -	COMPACT 10 DX technical data .....	16
2.6.3 -	COMPACT 12 DX technical data .....	17
2.7 -	LABELS.....	18
2.7.1 -	Common "yellow" labels.....	18
2.7.2 -	Common "orange" labels.....	18
2.7.3 -	Common "red" labels.....	19
2.7.4 -	Other labels .....	20
2.7.5 -	Model-specific labels .....	20
2.7.6 -	Country-specific labels .....	21
2.7.7 -	Machine label references .....	22
2.7.8 -	Label positions .....	23
<b>3 -</b>	<b>OPERATION.....</b>	<b>25</b>
3.1 -	HYDRAULIC CIRCUIT .....	25
3.1.1 -	Travel movement, steering movement.....	25
3.1.2 -	Scissor lifting cylinder.....	25
3.2 -	ELECTRIC CIRCUIT .....	26
3.3 -	SAFETY SYSTEMS .....	26
3.3.1 -	Details of the main safety systems.....	26
3.3.2 -	Load / overload control.....	26
3.3.3 -	Tilt control.....	26
3.3.4 -	Low, Medium and High travel speed .....	27
<b>4 -</b>	<b>USE.....</b>	<b>29</b>
4.1 -	GENERAL INSTRUCTIONS .....	29
4.1.1 -	General.....	29
4.1.2 -	MANUAL EXTENSIONS .....	29
4.1.3 -	Filling the fuel tank .....	30

4.2 -	LOADING, UNLOADING .....	31
4.2.1 -	Unloading by lifting.....	31
4.2.2 -	Unloading with ramps .....	31
4.2.3 -	Loading .....	32
4.2.4 -	Transport instructions. ....	32
4.3 -	BEFORE THE FIRST OPERATION .....	33
4.3.1 -	Getting to know the control stations.....	33
4.3.2 -	Pre-operation check.....	34
4.4 -	OPERATION.....	37
4.4.1 -	General recommendations.....	37
4.4.2 -	Operation from the ground.....	37
4.4.3 -	Operation from the platform .....	39
4.5 -	BACKUP LOWERING - EMERGENCY PLATFORM OPERATION .....	41
4.6 -	BRAKE RELEASE .....	41
4.7 -	STABILISERS.....	42
<b>5 -</b>	<b>MAINTENANCE .....</b>	<b>45</b>
5.1 -	GENERAL RECOMMENDATIONS .....	45
5.2 -	MAINTENANCE SYSTEM.....	45
5.3 -	MAINTENANCE PLAN .....	46
5.3.1 -	Consumables .....	46
5.3.2 -	Maintenance diagram .....	47
5.4 -	OPERATIONS .....	48
5.4.1 -	Summary table.....	48
5.4.2 -	Operating instructions .....	49
5.4.3 -	List of consumables .....	49
<b>6 -</b>	<b>OPERATING INCIDENTS .....</b>	<b>51</b>
6.1 -	PLATFORM LIFTING SYSTEM.....	51
6.2 -	TRAVEL SYSTEM .....	52
6.3 -	STEERING SYSTEM.....	52

<b>7 -</b>	<b>SAFETY SYSTEM .....</b>	<b>53</b>
7.1 -	CHASSIS BOX RELAY AND FUSE FUNCTION .....	53
7.2 -	SAFETY CONTACT FUNCTION .....	53
<b>8 -</b>	<b>HYDRAULIC DIAGRAMS .....</b>	<b>55</b>
8.1 -	COMPACT 8, 10 DX .....	56
8.2 -	COMPACT 12 DX .....	57
<b>9 -</b>	<b>WIRING DIAGRAM.....</b>	<b>59</b>
9.1 -	COMPACT 8, 10, 12 DX .....	59



# 1 - GENERAL RECOMMENDATIONS - SAFETY

## 1.1 - GENERAL WARNING

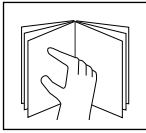

### 1.1.1 - Manual

The purpose of this manual is to help the operator to get to know HAULOTTE self-propelled lifts so as to use them efficiently and SAFELY. It cannot, however, replace the basic training necessary for any user of site plant.

The head of establishment has an obligation to ensure that operators know the instructions in the instruction manual. The head of establishment is also responsible for the implementation of the "user regulations" in force in the country of use.

Before using the machine, it is essential for safe use of the platform and its efficiency to familiarise yourself with all these instructions.

This instruction manual must be kept available to any operator. Additional copies can be supplied by the manufacturer on request.

### 1.1.2 - Labels

The potential dangers and instructions concerning the machine are indicated by labels and plates. It is necessary to read the instructions appearing on them.

All of the labels comply with the following colour code:

- The colour red indicates a potentially mortal danger.
- The colour orange indicates a danger which may cause serious injury.
- The colour yellow indicates a danger which may cause material damage or slight injury.

The head of the establishment must make sure that these labels are in good condition, and must take the necessary steps to keep them legible. Additional labels can be supplied on request by the manufacturer.

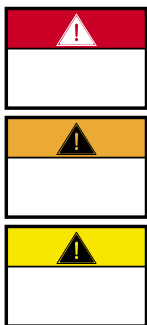

### 1.1.3 - Safety

Ensure that any person to whom you entrust the machine is capable of assuming the safety requirements of its use.

Avoid any working mode liable to jeopardise safety. Any use not compliant with the instructions could lead to risks and injury to people and damage to property.



**Caution !**

**In order to attract the reader's attention, the instructions will be preceded by this standardized sign.**

*The operating manual must be kept by the user throughout the machine's life including in the event of loan, hiring-out or re-sale.*

*Make sure that all the plates or labels relating to safety and danger are complete and legible.*

## 1.2 - GENERAL SAFETY INSTRUCTIONS

### 1.2.1 - Operators

The operators must be over 18 and must hold an operating permit issued by the employer after he has checked their medical fitness and after they have passed a practical lift driving/operating test.



**Caution !**

**Only trained operators can use Haulotte self-propelled lifts.**

There must be at least two operators so that one of them can:

- Intervene quickly if necessary.
- Take the controls in the event of an accident or breakdown.
- Monitor and prevent machines and pedestrians going round the lift.
- Guide the lift's operator if required.

### 1.2.2 - Environment

Never use the machine:

- On soft, unstable, cluttered ground.
- On ground with a bank greater than the permissible limit.
- With exposure to a wind greater than the permissible threshold. If used outside, make sure, using an anemometer, that the wind speed is less than or equal to the permissible threshold.
- Near power lines (find out the minimum distances depending on the voltage). In temperatures below  $-15^{\circ}\text{C}$  (particularly in cold stores). Consult us if it is necessary to work below  $-15^{\circ}\text{C}$ .
- In explosive areas.
- In an area not properly ventilated, since the exhaust gases are toxic.
- During storms (risk of lightning).
- At night if it is not equipped with the optional light.
- When there are very strong electromagnetic fields (radar, mobiles and high currents).

**DO NOT TRAVEL ON PUBLIC HIGHWAYS.**

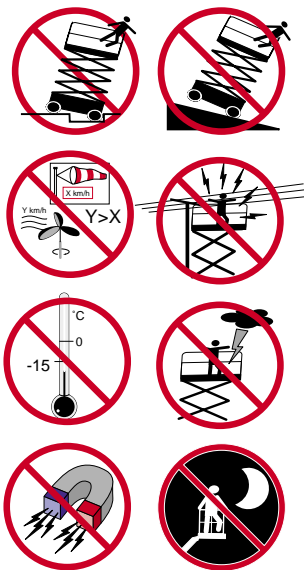

### 1.2.3 - Using the machine

It is important to ensure that in normal use, that is lift operation, the lift post selection key remains in the lift position so as to be able to control the lift from the platform. In the event of a problem on the platform, a person present and trained in emergency/standby manoeuvres can assist by putting the key in the ground control position.

Do not use the machine with:

- A load greater than the nominal load.
- More people than the authorized number.
- A lift lateral force greater than the permissible value.
- A wind greater than the permissible speed.



 **Caution !**

**Never use the platform as a crane, goods lift or lift. Never use the platform to pull or tow.**

In order to avoid any risk of a serious fall, it is essential for operators to comply with the following instructions:

- Hold on to the guard rails firmly when the lift is being raised or driven.
- Wipe any traces of oil or grease off the steps, floor and hand rails.
- Wear individual protective equipment suited to the working conditions and local regulations in force, particularly when working in a dangerous area.
- Do not neutralise the limit switches on the safety devices.
- Avoid hitting fixed or moving obstacles.
- Do not increase the working height by using ladders or other accessories.
- Do not use the guard rails as a means of access for getting onto and off the platform (use the steps provided for this purpose on the machine).
- Do not climb onto the guard rails when the platform is in the raised position.
- Do not drive the lift at high speed in areas which are narrow or not cleared.
- Do not use the machine without fitting the lift's protective bar or without closing the safety gate.
- Do not climb onto the covers.

In order to avoid risks of overturning, it is essential for operators to comply with the following instructions:

- Do not neutralise the limit switches on the safety devices.
- Avoid operating the control levers for one direction in the opposite direction without stopping in the " 0 " position (in order to stop during travelling, move the manipulator's lever gradually).
- Comply with the maximum load as well as the number of people authorized on the lift.
- Distribute the loads and place them if possible in the centre of the lift.
- Verify that the ground can take the pressure and load per wheel.
- Avoid hitting fixed or moving obstacles.
- Do not drive the lift at high speed in areas which are narrow or not cleared.
- Do not drive the lift in reverse (lack of visibility).
- Do not use the machine with a cluttered lift.
- Do not use the machine with equipment or objects suspended from the guard rails.
- Do not use the machine with elements which could increase the wind load (e.g.: panels).
- Do not carry out machine maintenance operations when it is raised without having put in place the necessary safety devices (travelling crane, crane).
- Carry out the daily checks and monitor proper operation during periods of use.
- Protect the machine from any unsupervised intervention when it is not in service.

**NOTE :** *Do not tow the lift (it has not been designed for that and must be transported on a trailer).*

## 1.3 - RESIDUAL RISKS

### 1.3.1 - Risks of jolting - Overturning

The risks of jolting or overturning are considerable in the following situations:

- sudden operation of the control levers,
- overload of the lift,
- ground weakness (Beware of thawing in winter),
- gusting wind,
- hitting an obstacle on the ground or high up,
- working on quays, bays, pavements, etc...

Allow a sufficient stopping distance:

- 3 metres at high speed,
- 1 metre at low speed.

### 1.3.2 - Electrical risks

The electrical risks are considerable in the following situations:

- hitting a power line,
- use in stormy weather.

### 1.3.3 - Risks of explosion or burning

The risks of explosion or burning are considerable in the following situations:

- work in an explosive or flammable atmosphere,
- filling the fuel tank near to flames,
- contact with the hot parts of the engine,
- using a machine with hydraulic leaks.

### 1.3.4 - Risks of collision

- Risks of crushing people present in the area in which the machine is operating (during travelling or operation of the equipment).
- Evaluation by the operator, before any use, of the risks above him.

## 1.4 - VERIFICATIONS

Comply with the national regulations in force in the country of use.

For FRANCE: Order of June 9th 1993 + circular DRT 93-22 September 1993 specifying:

### 1.4.1 - Routine verifications

The machine must be the subject of routine inspections every 6 months so that any defect liable to cause an accident is detected.

These inspections must be carried out by an organisation or personnel specially designated by the head of establishment and under the latter's responsibility (company's personnel or not) (Articles R 233-5 and R 233-11 of the Code du Travail).

The result of these inspections must be entered in a safety register opened by the head of establishment and kept constantly available to the works inspector and safety committee of the establishment, if there is one, as well as a list of the specially designated personnel (Article R 233-5 of the Code du Travail).

*NOTE :* Such register can be obtained from the trade organisations and some of them can be obtained from the OPPBTP or private prevention organisations.

The people designated must be experienced in the field of risk prevention (Articles R 233-11 of Decree n° 93-41).



#### **Caution !**

**If the machine has a 220 V power point, max. 16 A, it is essential for the extension lead to be connected to a mains outlet protected by a 30 mA quick-trip circuit-breaker.**

It is forbidden to allow any worker to proceed, during the operation of the machine, with any verification whatsoever (Article R 233-11 of the Code du Travail).

#### **1.4.2 - Examination of suitability of a machine**

The head of the establishment in which this equipment is put into service must make sure of the suitability of the machine, that is, that it is appropriate for the works to be carried out safely and that it is used in accordance with the instruction manual. In addition, in the above-mentioned French order of June 9th 1993, problems associated with hiring, the examination of the state of conservation, verification at the time of putting back into service after repair, as well as coefficient 1.25 static test and coefficient 1.1 dynamic test conditions are mentioned. Each person responsible using the machine must acquaint himself and follow the requirements of this decree.

#### **1.4.3 - State of conservation**

Detect any damage liable to be the cause of dangerous situations (safety devices, load limiters, tilt monitor, leaks from cylinders, deformation, condition of welds, tightness of bolts, hoses, electrical connections, condition of tyres, excessive mechanical play).

*NOTE :* *In the case of hiring, the person responsible using the hired machine has the responsibility of examining the state of conservation and for examining suitability. He must check with the hirer that the routine general verifications and verifications before putting into service have indeed been carried out.*

### **1.5 - REPAIRS AND ADJUSTMENTS**

Major repairs, maintenance work or adjustments on the safety elements or systems (concerns mechanics, hydraulics and electricity).

They must be carried out by PINGUELY-HAULOTTE personnel or personnel working on behalf of PINGUELY-HAULOTTE who must use original parts only.

Any modification outside PINGUELY-HAULOTTE's control is not authorised.

The manufacturer is not liable if original parts are not used or if the work specified above is not carried out by PINGUELY-HAULOTTE approved personnel.

### **1.6 - VERIFICATIONS AT THE TIME OF PUTTING BACK INTO SERVICE**

To be carried out after:

- major removal/refitting,
- a repair involving the machine's essential parts,
- any accident caused by the failure of an essential part.

It is necessary to proceed with an examination of suitability, an examination of the state of conservation, a static test, a dynamic test (see coefficients, § 1.4.2, page 5).



## 2 - PRESENTATION



The self-propelled platform is designed for all overhead work, within the limits of its characteristics.

The main operating station is on the platform extension. The backup station and emergency control are on the ground.

### 2.1 - IDENTIFICATION

A plate on the chassis bears all the indications (engraved) for machine identification.

Fig. 1 - Manufacturer's plate

<b>Pinguely - Haulotte</b> 	
La Péronnière, BP9, 42152 L'Horme - France	
	
<b>ENGIN</b>	<input style="width: 100%;" type="text"/>
<b>TYPE</b>	<input style="width: 100%;" type="text"/>
<b>N° SERIE</b>	<input style="width: 100%;" type="text"/>
<b>MASSE</b>	<input style="width: 100%;" type="text"/> <b>kg</b>
<b>ANNEE DE CONSTRUCTION</b>	<input style="width: 100%;" type="text"/>
<b>PUISSANCE NOMINALE</b>	<input style="width: 100%;" type="text"/> <b>kW</b>
<b>CHARGE MAXI</b>	<input style="width: 100%;" type="text"/> <b>kg</b>
<b>NOMBRE PERS. + CHARGE</b>	<input style="width: 100%;" type="text"/> <b>P + kg</b>
<b>FORCE LATERALE MAXI</b>	<input style="width: 100%;" type="text"/> <b>N</b>
<b>VITESSE DU VENT MAXI</b>	<input style="width: 100%;" type="text"/> <b>m/s</b>
<b>DEVERS MAXI</b>	<input style="width: 100%;" type="text"/> <b>degrés</b>
<b>PENTE GRAVISSABLE MAXI</b>	<input style="width: 100%;" type="text"/> <b>%</b>
7814 324 a	

REMINDER: For all information, intervention or spare parts requests, please specify the machine type and serial number.

**2.2 - MAIN COMPONENTS**

Fig. 2 - Position of the main components

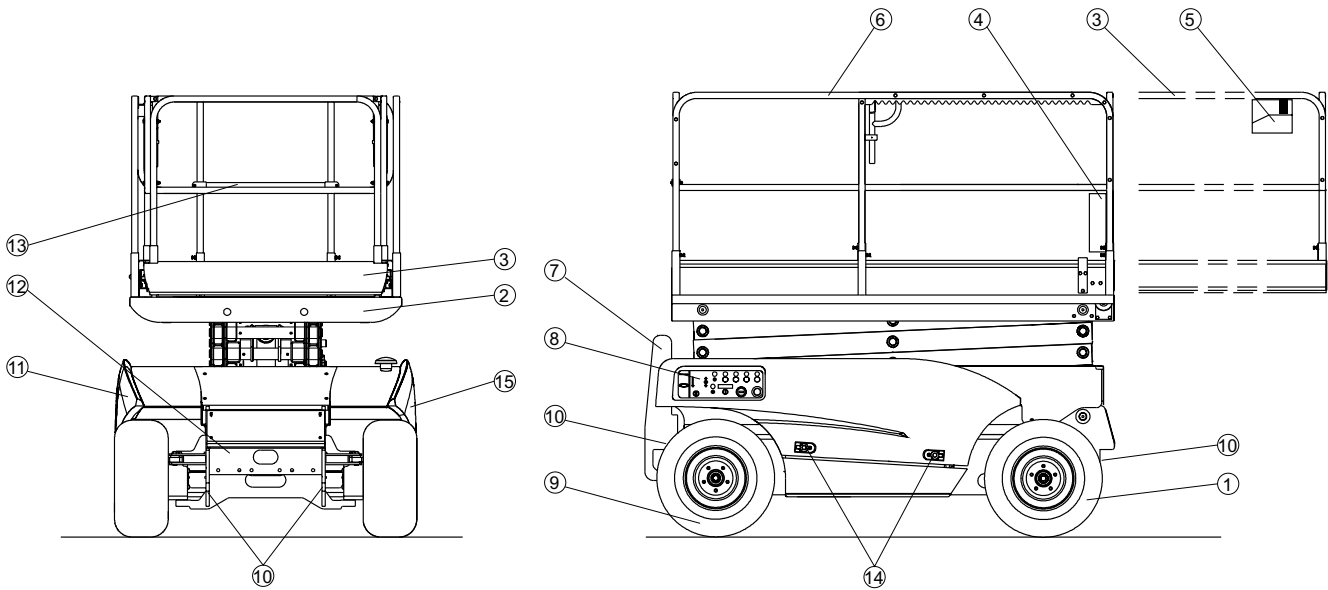

<b>1- Front steering wheels</b>	<b>9- Rear wheels</b>
<b>2- Platform</b>	<b>10- Anchoring points</b>
<b>3- Extension</b>	<b>11- Hydraulic tank</b>
<b>4- Document case</b>	<b>12- Chassis</b>
<b>5- Platform control desk</b>	<b>13- Platform access bar</b>
<b>6- Safety barrier</b>	<b>14- Cover locking tab</b>
<b>7- Platform access ladder</b>	<b>15- Motor box</b>
<b>8- Chassis control desk</b>	

**2.3 - DESCRIPTION**

"HAULOTTE SCISSOR" platforms are work platforms surrounded by protective barriers. They can be lifted or lowered by a hydraulic cylinder acting on scissors with three, four or five sections, depending on the model, which support the work platform.

The chassis has two braked drive and steering wheels at the front and two braked drive wheels at the back, equipped with puncture-proof tyres (inflated with polyurethane foam) with a cross-country tread.

Each motor is supplied with power by a thermal diesel engine. All control and power devices are installed in two side boxes, including:

- the hydraulic tank and filters,
- the air-cooled thermal motor and hydraulic pump,
- the fuel tank,
- the hydraulic distribution set,
- the thermal motor ignition battery,
- the electric control cubicle.

The tilt detector is between the scissor arms.

The electric cubicle on the chassis controls:

- station selection,
- motor fault light indicators,
- hour counter,
- platform up and down movement,
- start and stop of the thermal motor,
- emergency stop of all movements.



The three movements: travel, steering and platform lifting are controlled by hydraulics.

Travel and lifting are in proportional command.

Steering is activated by a double-action cylinder.

Option:

- Stabilisers: a set of four support cylinders fixed to the chassis and controlled from the platform enabling increase of platform stability (section § 4.7, page 42).

2.4 - WORKING AREA

2.4.1 - Compact 8 DX

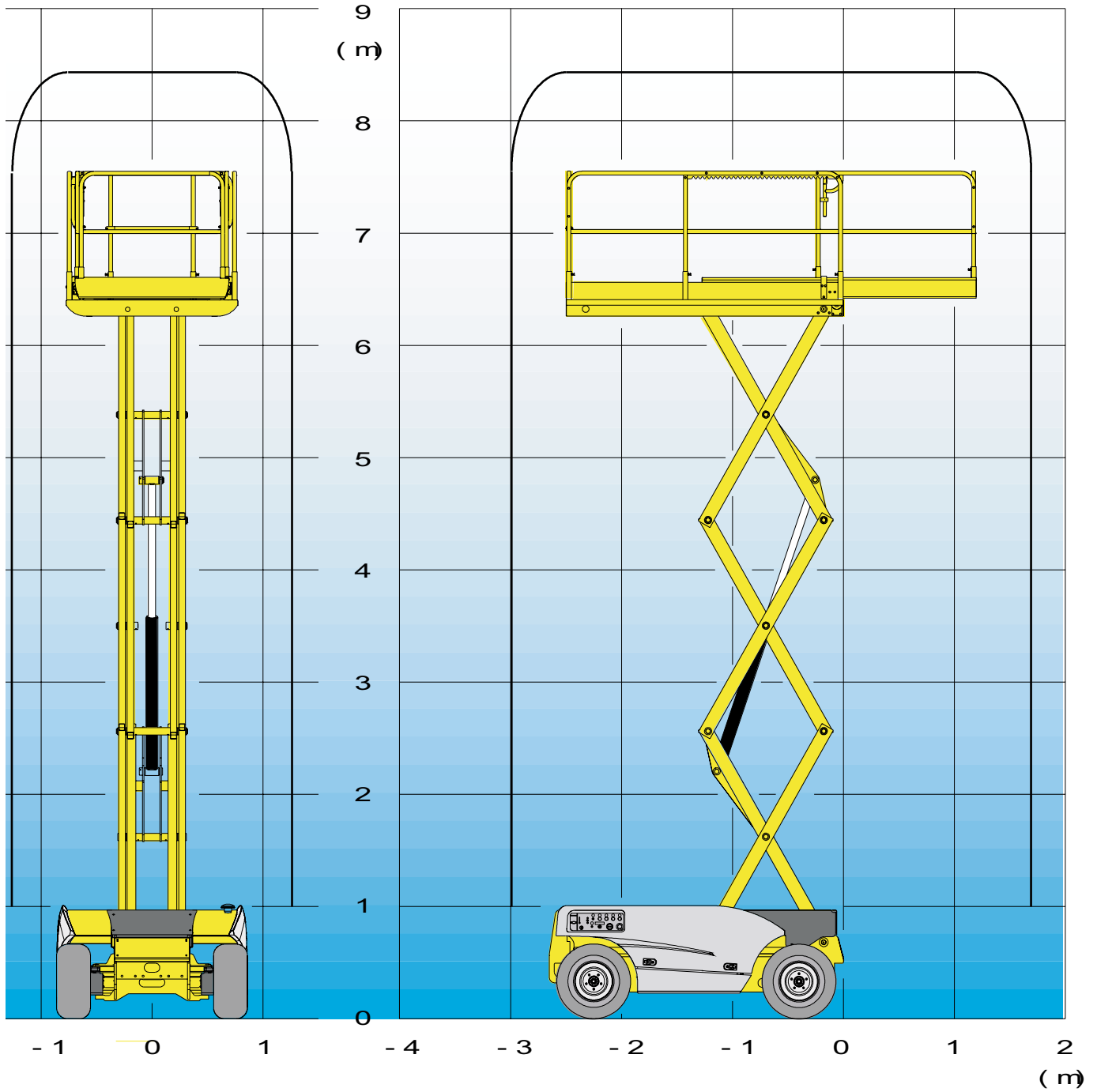

### 2.4.2 - Compact 10DX

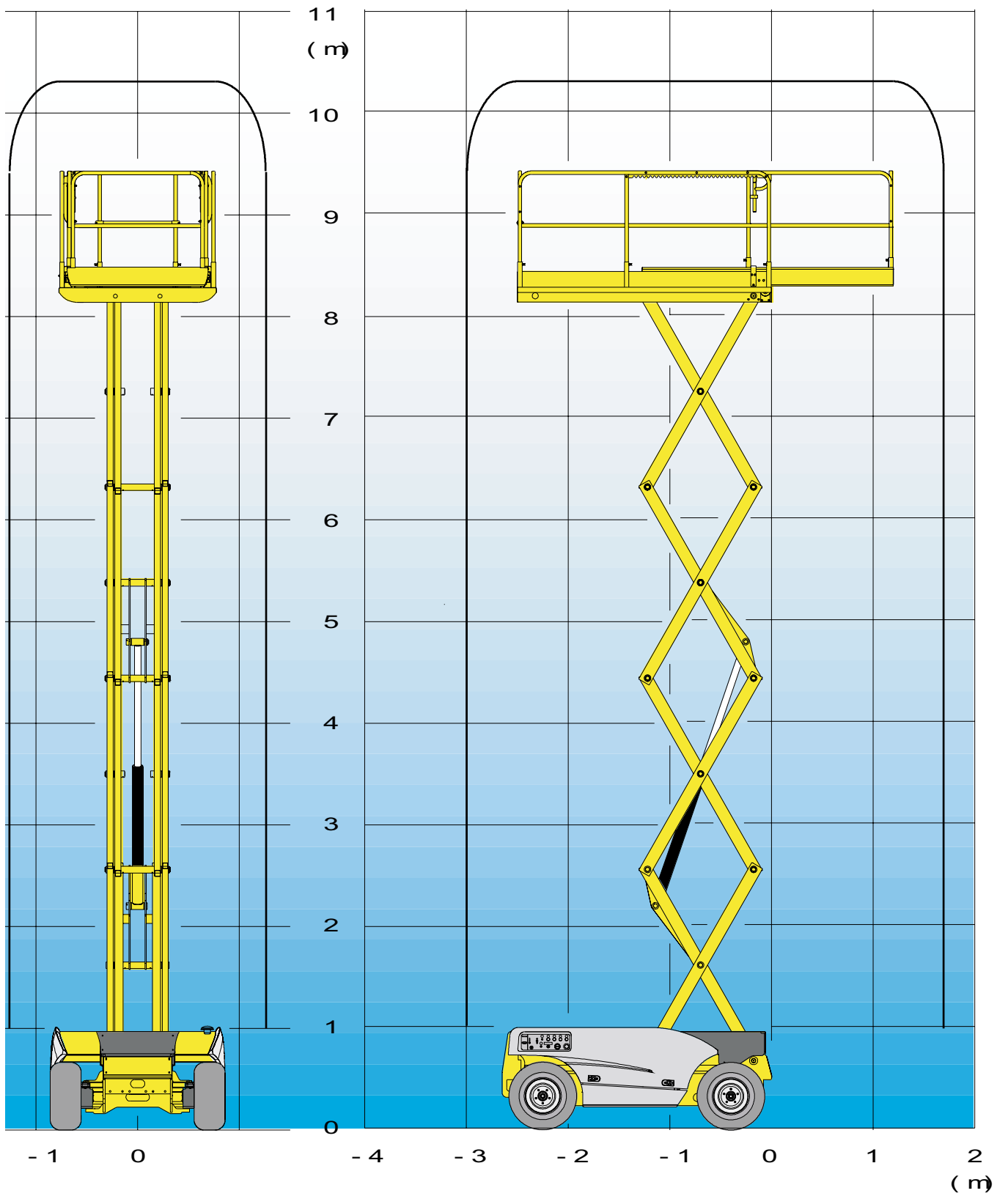

2.4.3 - Compact 12DX

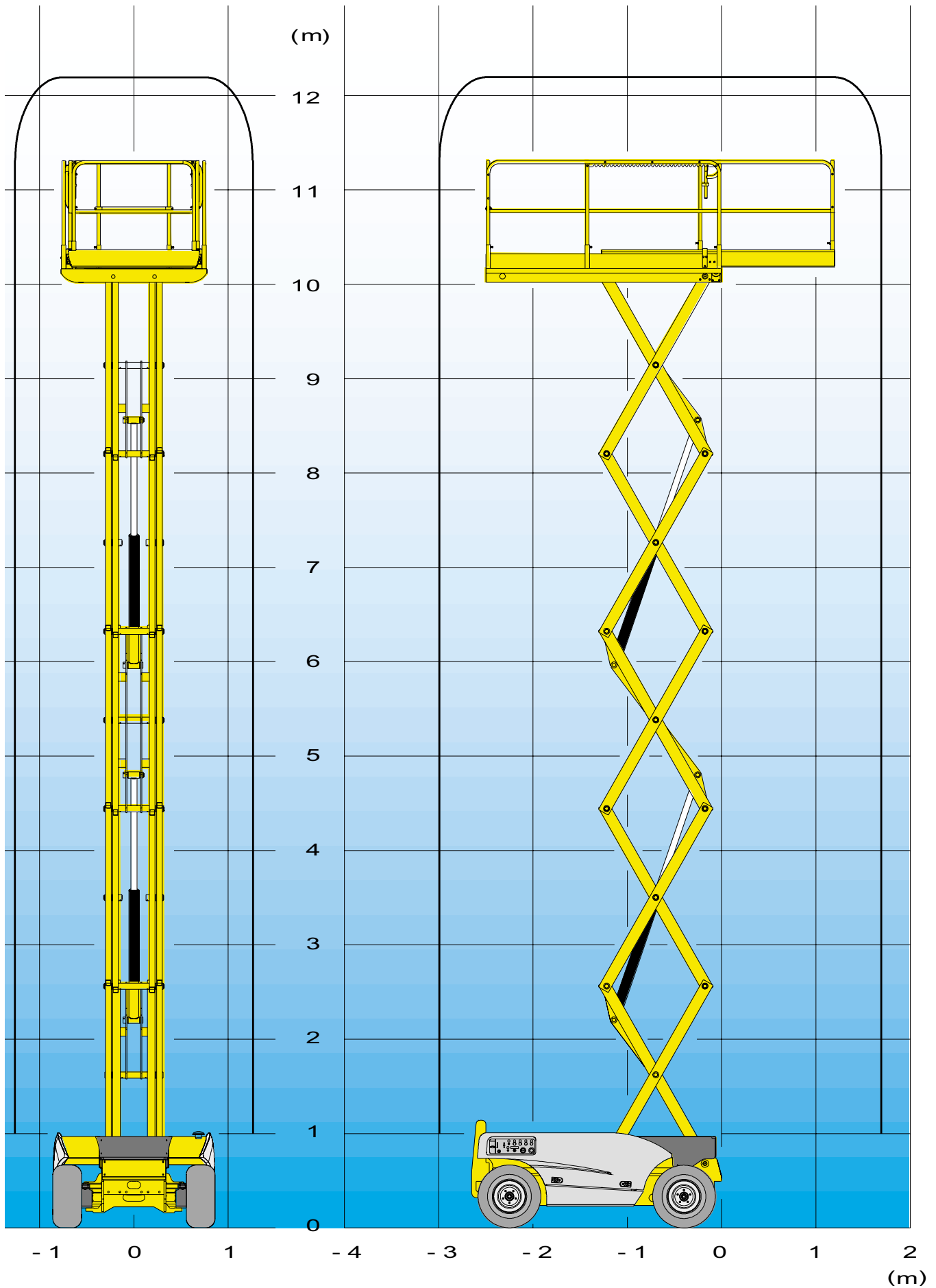

**2.5 - SIZE**

**2.5.1 - COMPACT 8DX size**

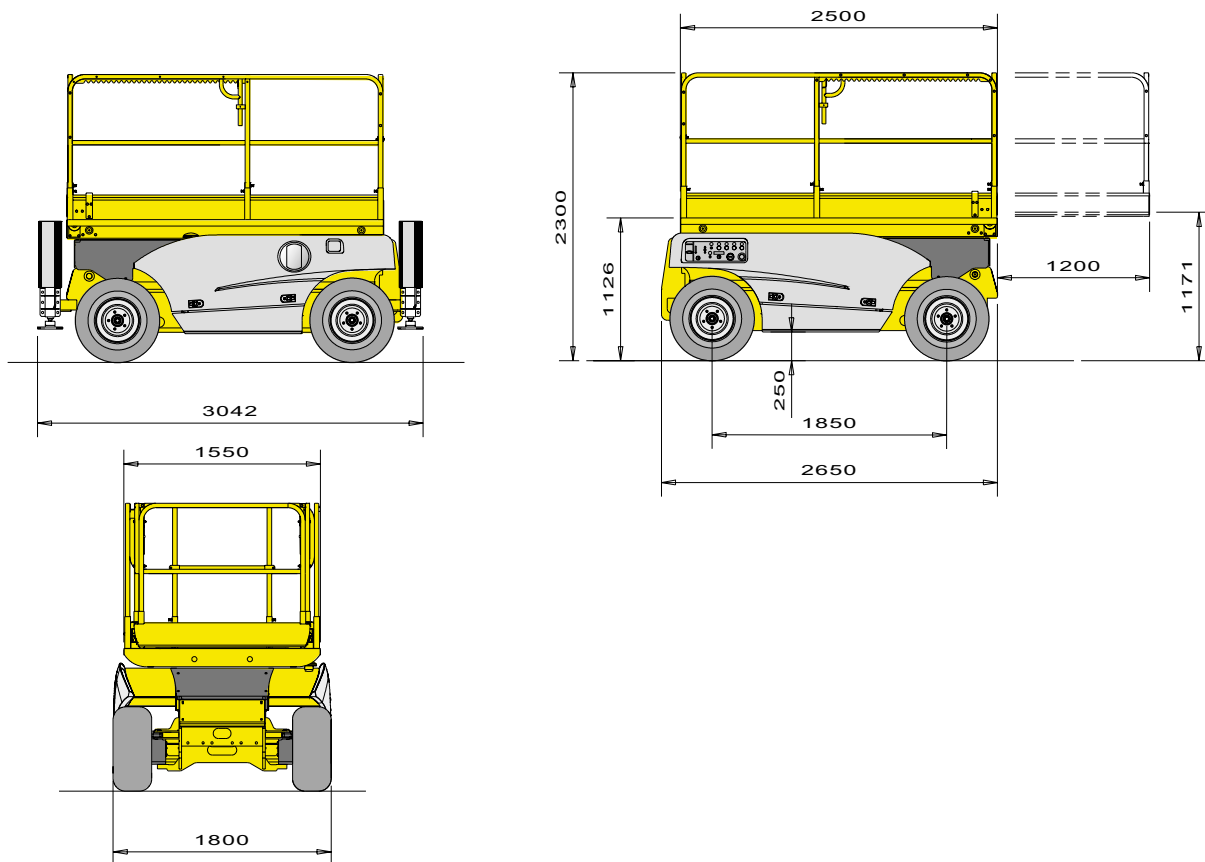

**2.5.2 - COMPACT 10DX size**

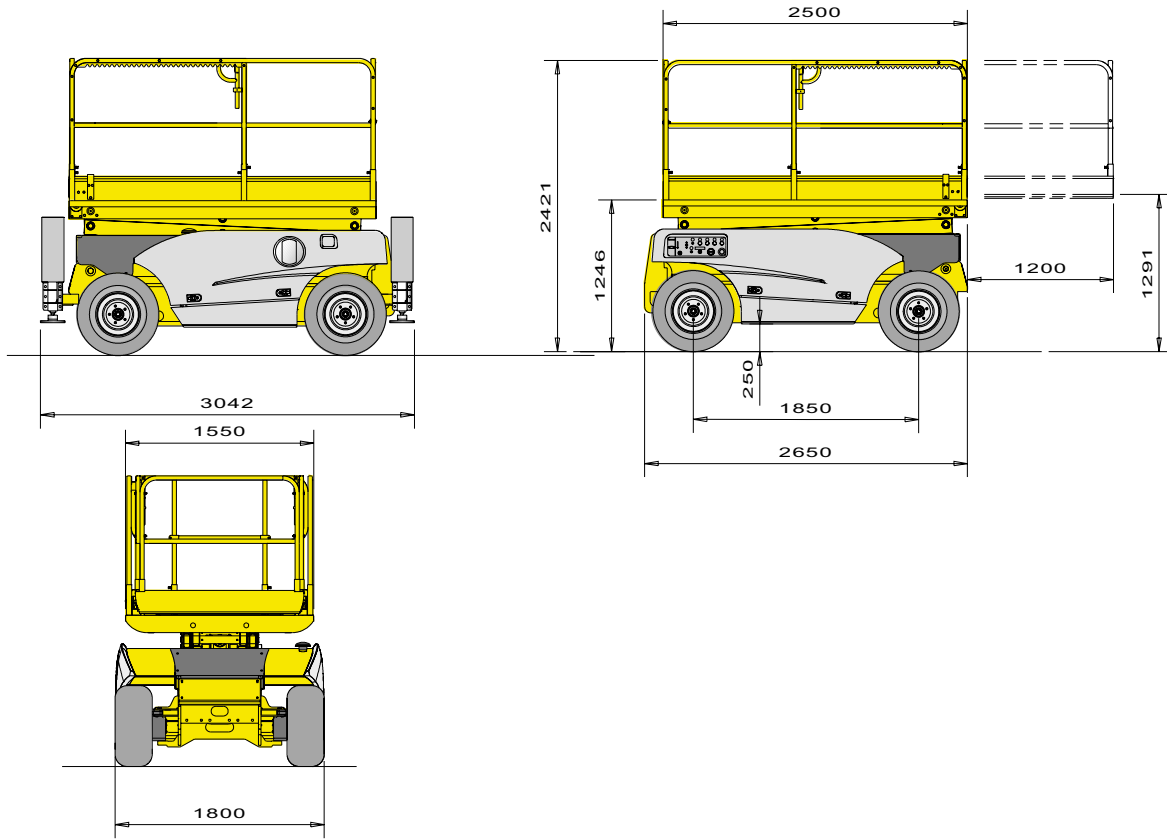

**2.5.3 - COMPACT 12DX size**

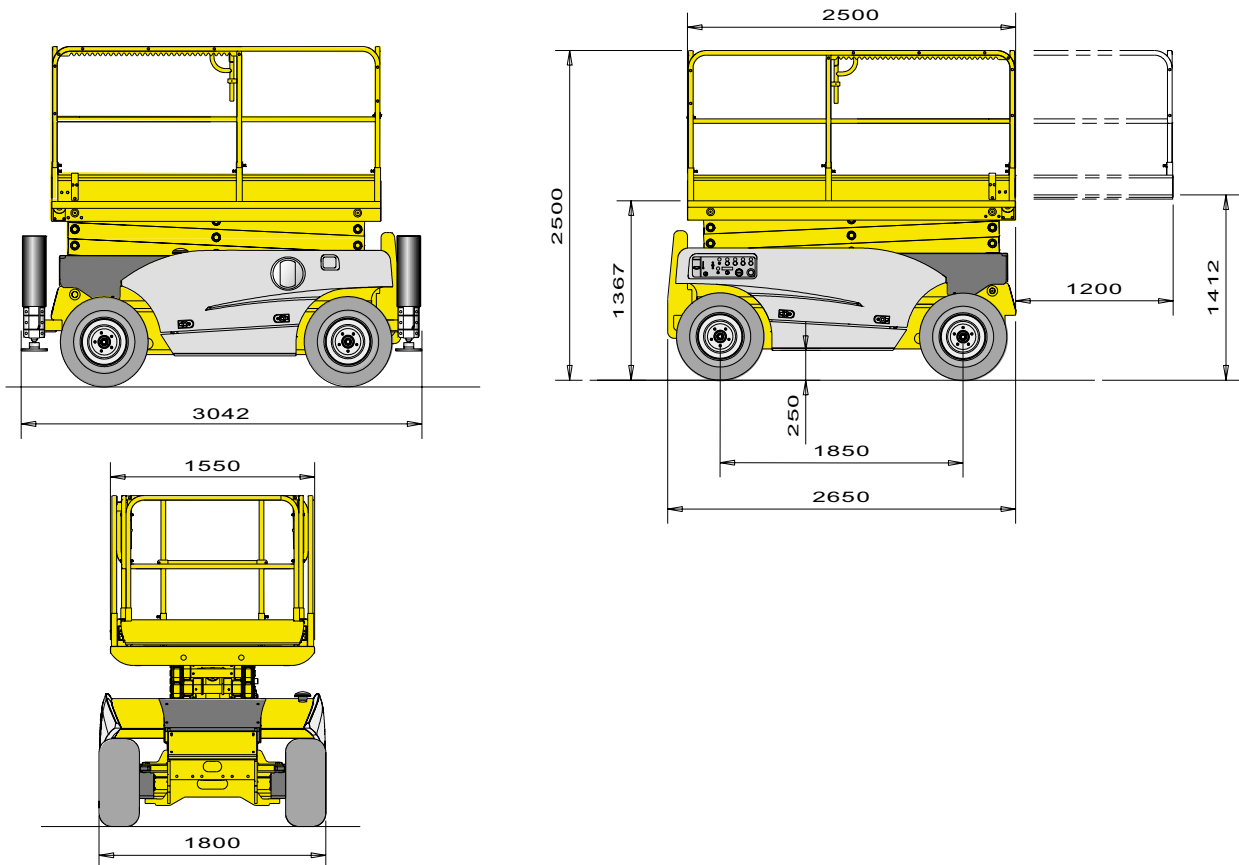

**2.6 - TECHNICAL DATA****2.6.1 - COMPACT 8 DX technical data**

<b>Characteristic</b>	<b>COMPACT 8 DX</b>
Working height	8.4 m
Floor height	6.4 m
Extension	1.2 m
Capacity	565 Kg (3 people) including 150 Kg on extension
Weight	2980 Kg
Width	1.80 m
Height	2.3 m
Length	2.65 m
Speed, platform lowered	5.5 Km/h
Speed, platform lifted	1 Km/h
Up/down time	35/35 sec
Allowed ramp	40%
Speed control	proportional command
Drive wheels	4X4
External turning radius	3.68 m
Wheelbase	1.85 m
Chassis floor clearance	25 cm
Diesel tank	60 l
Hydraulic tank	80 l
Pneumatics	26x12-12 PR
General calibration hydraulic pressure	240 bar
Travel calibration hydraulic pressure	PV 240 bar, MV/GV 175 bar
Hydraulic pump	11+11 cm <sup>3</sup> /rev
Thermal motor	17.9KW at 2400 rpm
Tilt	3°
Maximum wind speed	45 Km/h
Max. lateral force	40 daN

**2.6.2 - COMPACT 10 DX technical data**

<b>Characteristic</b>	<b>COMPACT 10 DX</b>
Working height	10.2 m
Floor height	8.2 m
Extension	1.2 m
Capacity	565 kg including 150 kg on the extension
Weight	3300 Kg
Width	1.80 m
Height	2.42 m
Length	2.65 m
Speed, platform lowered	5.5 Km/h
Speed, platform lifted	1Km/h
Up/down time	35/35 sec
Allowed ramp	40%
Speed control	proportional command
Drive wheels	4X4
External turning radius	3.68 m
Wheelbase	1.85 m
Chassis floor clearance	25 cm
Diesel tank	60 l
Hydraulic tank	80 l
Pneumatics	26x12-12
General calibration hydraulic pressure	240 bar
Travel calibration hydraulic pressure	PV 240 bar, MV/GV 175 bar
Hydraulic pump	11+11 cm <sup>3</sup> /rev
Thermal motor	17.9KW at 2400 rpm
Tilt	3°
Maximum wind speed	45 Km/h
Max. lateral force	40 daN



**2.6.3 - COMPACT 12 DX technical data**

<b>Characteristic</b>	<b>COMPACT 12 DX</b>
Working height	12.14 m
Floor height	10.14 m
Extension	1.2 m
Capacity	450 Kg including 150 kg on the extension
Weight	3760 kg
Width	1.80 m
Height	2.55 m
Length	2.65 m
Speed, platform lowered	5.5 Km/h
Speed, platform lifted	1Km/h
Up/down time	35/35 sec
Allowed ramp	40%
Speed control	proportional command
Drive wheels	4X4
External turning radius	3.68 m
Wheelbase	1.85 m
Chassis floor clearance	25 cm
Diesel tank	60 l
Hydraulic tank	80 l
Pneumatics	26x12-12
General calibration hydraulic pressure	240 bar
Travel calibration hydraulic pressure	PV 240 bar, MV/GV 175 bar
Hydraulic pump	11+11 cm <sup>3</sup> /rev
Thermal motor	17.9KW at 2400 rpm
Tilt	3°
Maximum wind speed	45 Km/h
Max. lateral force	40 daN

2.7 - LABELS

2.7.1 - Common "yellow" labels

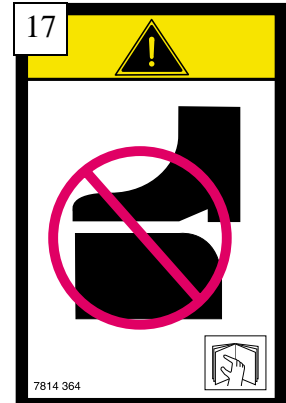
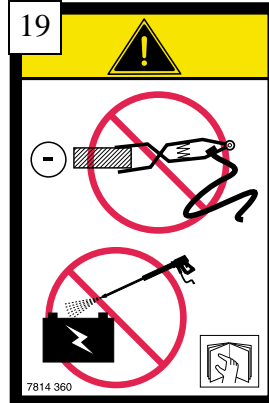
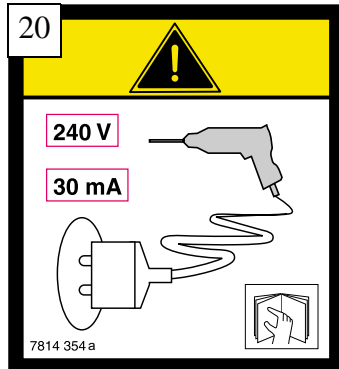

2.7.2 - Common "orange" labels

7	
<b>RECOMMENDATIONS FOR USE</b>	
BEFORE USING THIS MACHINE THE OPERATOR MUST	
<ol style="list-style-type: none"> <li>1 - Read and understand the information in the operator's manual and the information marked on the machine, and become familiar with the controls.</li> <li>2 - Receive training and practical experience in operating the machine, under the employer's supervision.</li> <li>3 - Ensure that maintenance is performed according to the manufacturer's instructions.</li> <li>4 - Refrain from using the machine in the event of any malfunction.</li> <li>5 - Not wash the electrical components with a washer pressure.</li> <li>6 - Not remove any parts which might affect the stability.</li> <li>7 - Not modify the machine without the manufacturer's approval.</li> <li>8 - Not use the machine as a welding earth.</li> <li>9 - Not weld on the machine without first disconnecting the battery terminals. See the instructions in the maintenance manual.</li> </ol>	
<b>DAILY INSPECTION</b>	
<ol style="list-style-type: none"> <li>1 - Check the level of diesel fuel (for diesel engine platforms).</li> <li>2 - Check that there are no apparent defects (hydraulic leaks, loose bolts, loose electric connections)</li> <li>3 - Check that the tilt indicator operates correctly by sounding the buzzer.</li> </ol>	
<b>INSTRUCTIONS BEFORE USE</b>	
<ol style="list-style-type: none"> <li>1 - Remove the rotation locking pin (if there is a turntable).</li> <li>2 - <b>IMPORTANT</b> when using the AC power line to the work platform, the power plug must be connected to an electrical installation protected by a 30 mA circuit breaker (C15 100 standard).</li> </ol>	
<b>START-UP</b>	
<ol style="list-style-type: none"> <li>1 - Turn the battery isolater switch to the "on" position.</li> <li>2 - Unlock the emergency stop button then press the starter button.</li> <li>3 - If the machine does not start, wait 10 seconds then repeat the operation.</li> </ol>	
<p>THE MACHINE <b>MUST NOT BE USED</b> WHILE CHARGING THE BATTERIES</p>	
7814 345	

### 2.7.3 - Common "red" labels

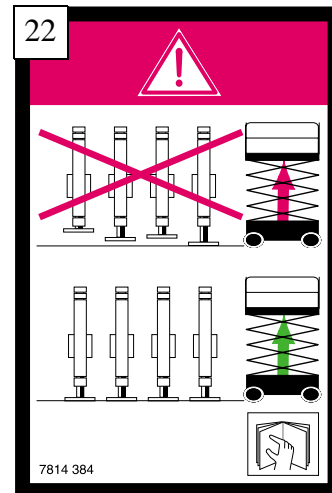
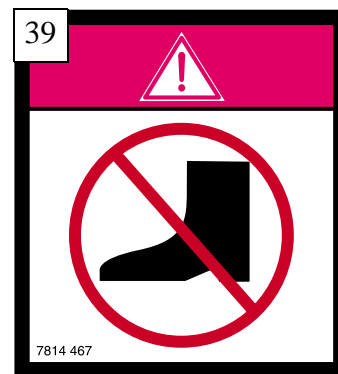
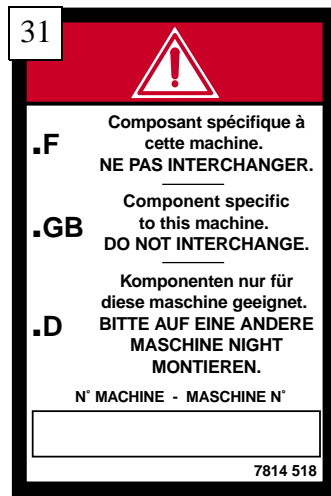
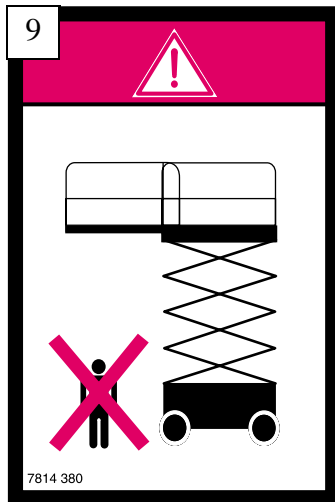
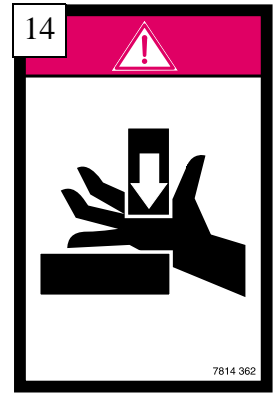
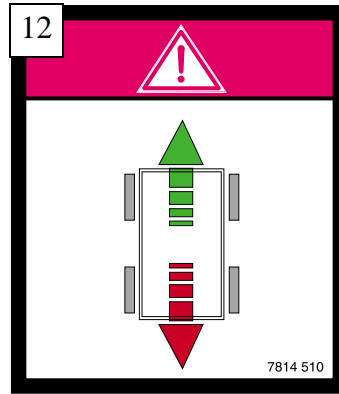
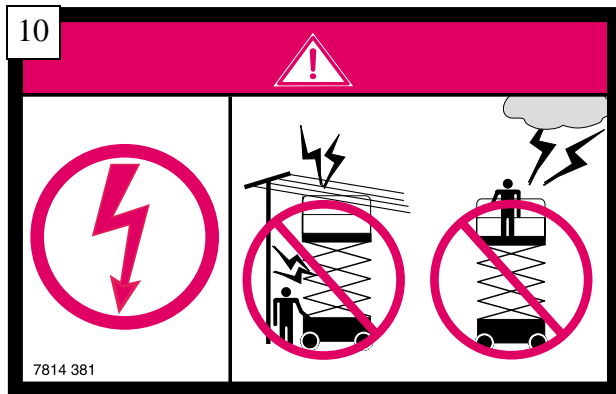

### 2.7.4 - Other labels

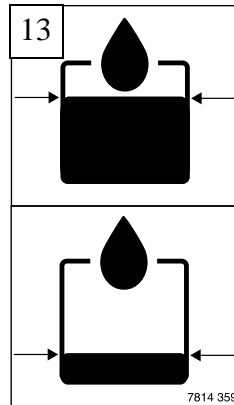
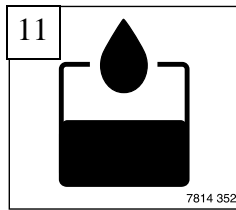
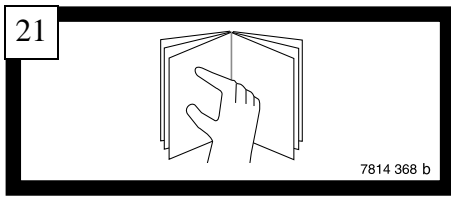

### 2.7.5 - Model-specific labels

#### 2.7.5.1 - Compact 8 DX

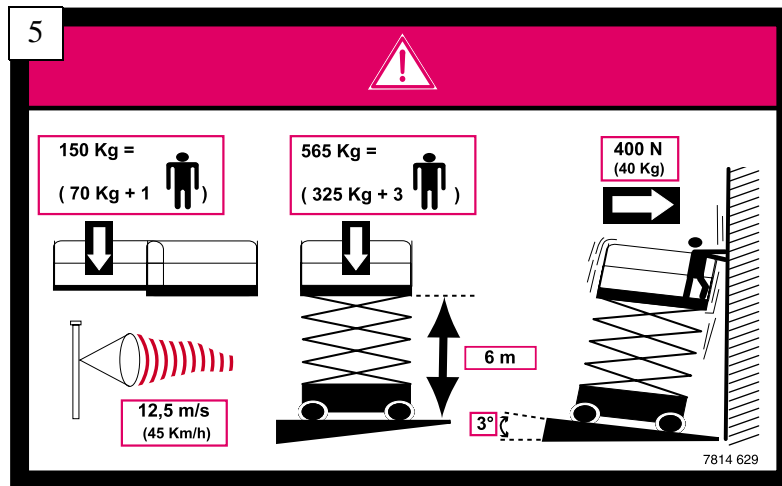

#### 2.7.5.2 - Compact 10DX

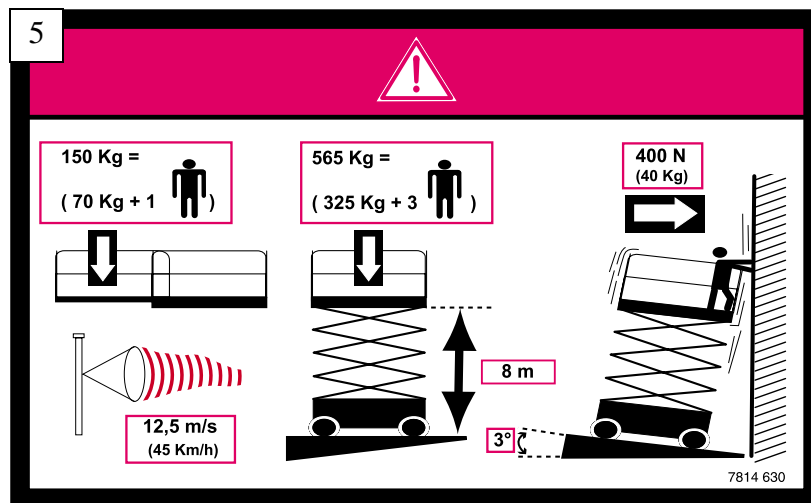

2.7.5.3 - Compact 12DX

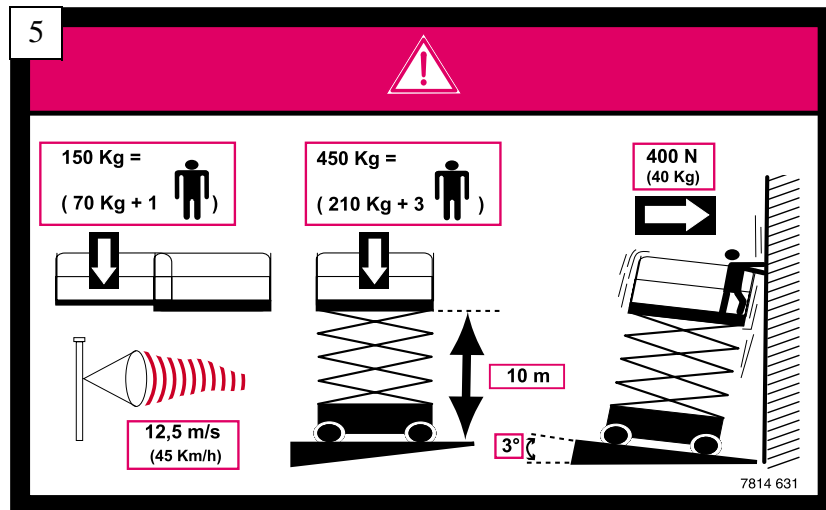

2.7.6 - Country-specific labels

2.7.6.1 - Australia

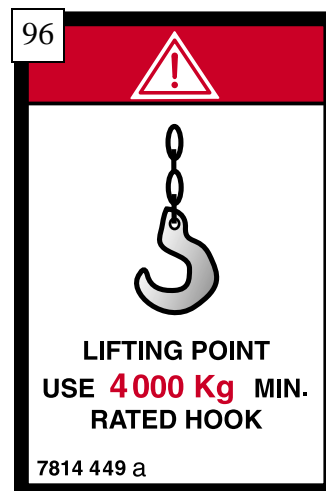
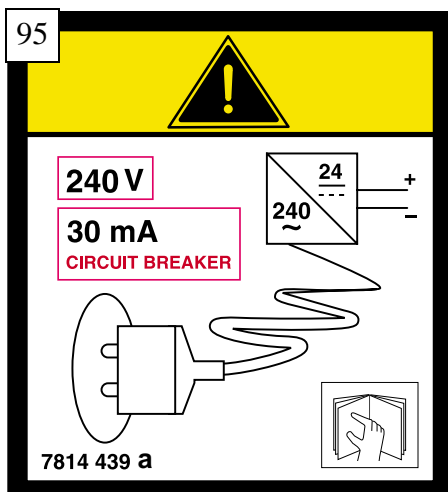

**2.7.7 - Machine label references**

<b>Ref</b>	<b>Code</b>	<b>Qty</b>	<b>Description</b>
01	307814 4970	1	Heat burn danger
02	3078146350	4	"Compact 8 DX" label
02	3078146360	4	"Compact 10 DX" label
02	3078146370	4	"Compact 12 DX" label
05	307814 6290	2	COMPACT 8 DX floor height + load
05	307814 6300	2	COMPACT 10 DX floor height + load
05	307814 6310	2	COMPACT 12 DX floor height + load
07	307814 3420	1	Operating instructions (French)
07	307814 3430	1	Operating instructions (Spanish)
	307814 3440		Operating instructions (German)
	307814 3450		Operating instructions (English)
	307814 3460		Operating instructions (Italian)
	307814 3470		Operating instructions (Dutch)
	307814 4940		Operating instructions (Danish)
	307814 5540		Operating instructions (Finnish)
	307814 5940		Operating instructions (Swedish)
307814 5830	Operating instructions (Portuguese)		
08	307814 3240 a	1	Manufacturer's plate (French)
08	307814 6570	1	Manufacturer's plate (Spanish)
	307814 6560		Manufacturer's plate (German)
	307814 6550		Manufacturer's plate (English)
	307814 6580		Manufacturer's plate (Italian)
	307814 6590		Manufacturer's plate (Dutch)
	307814 6630		Manufacturer's plate (Danish)
	307814 6600		Manufacturer's plate (Finnish)
	307814 6610		Manufacturer's plate (Swedish)
307814 6620	Manufacturer's plate (Portuguese)		
09	307814 3800	2	No stopping in the working area
10	307814 3810	1	Danger: Risk of electrocution
11	307814 3520	1	Hydraulic oil
12	307814 5100	2	Travel direction
13	307814 3590	1	High and low level hydraulic oil
14	307814 3620	2	Danger: Risk of hand crushing
17	307814 3640	2	Do not stand on the cover
19	307814 3600	2	Do not use as a welding station
20	307814 3540 a	1	Connect to a 220V socket
21	307814 3680 b	1	Read the manual
22	307814 3840	4	Stabilisation of 4 cylinders
23	3078145660	1	Bottom control desk
24	3078146130	1	Top control desk
27		1	CE manual
28		1	SP catalogue
31	307814 5180	1	Do not interchange
39	307814 4670	1	Danger: Risk of foot crushing
50	1250127590	3	Haulotte design
95	3078144390	1	Fuel filling
96	3078144490	4	Sling load
97	3078144360	1	Do not go down slopes at high speed
98	3078144280	1	The 4 cylinders must be retracted
99	3078146330	2	4WD design

2.7.8 - Label positions

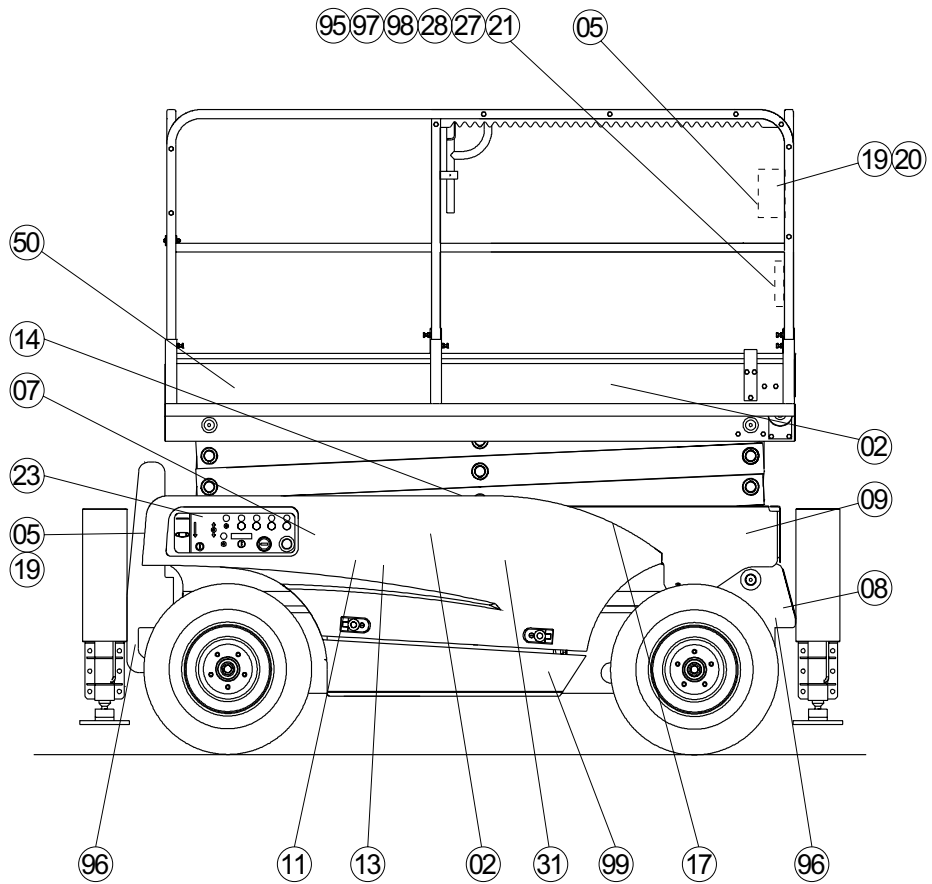
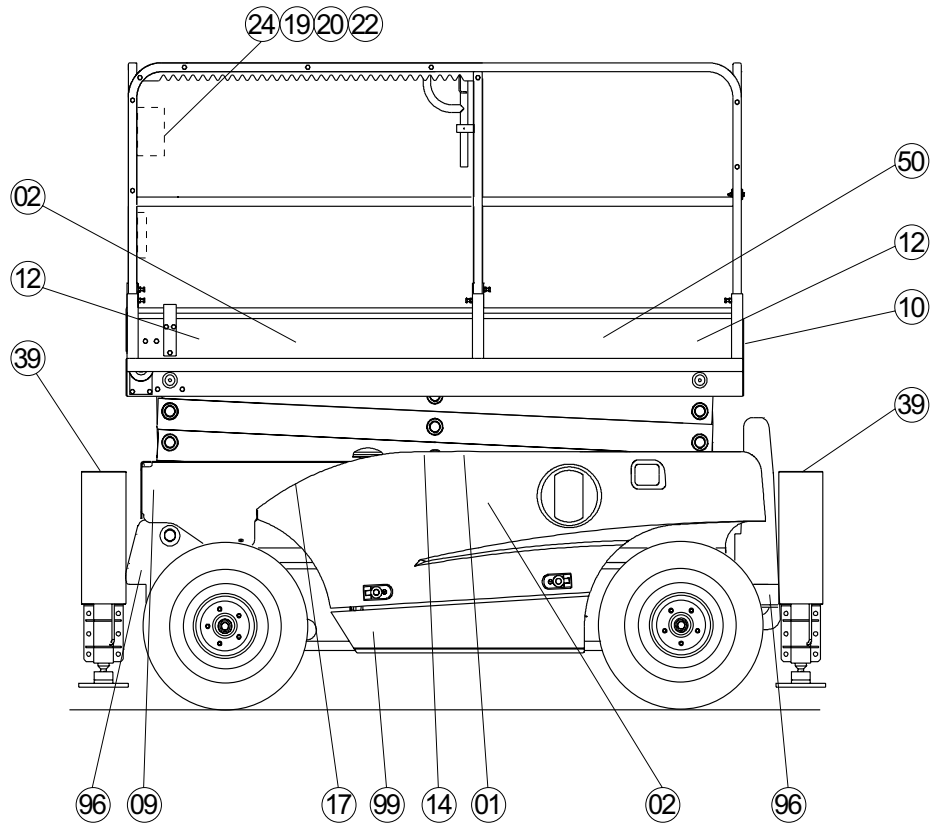





## 3 - OPERATION

### 3.1 - HYDRAULIC CIRCUIT

All machine movements are controlled by hydraulic power, supplied by two gear pumps driven by a thermal motor.

In the event of a breakdown, manual emergency action enables lowering of the scissors.

A return filter on the return line protects the installation against contamination.

Only one movement is possible at a time.

#### 3.1.1 - Travel movement, steering movement

Travel is controlled by on/off distributing valves, using a proportional command distributing valve to enable gradual movement.

	<i>Supply motor</i>
4 x 4 version	<p>Four hydraulic motors drive the wheels. Three speeds (high, medium and low) are controlled by a switch.</p> <p><u>High speed</u>: the two motors on the fixed axle are supplied in parallel by the two pump bodies; the steering axle is in freewheel.</p> <p><u>Medium speed</u>: the four motors on the fixed axle are supplied in parallel by the two pump bodies</p> <p><u>Low speed</u>: Each side receives half the output supplied by one pump body. All the motors are supplied in parallel. A hydraulic differential blockage on each side can be used in low and high speed.</p>

Steering only is controlled by an on/off distributing valve.

#### 3.1.2 - Scissor lifting cylinder

The cylinder is equipped with a flap electrovalve welded to the body.

The lifting movement is controlled by an on/off electrovalve and gradual movement is controlled by the proportional electrovalve.

The lowering movement is controlled by one (2 for the twelve metre version) on/off electrovalve mounted on each cylinder.



**Caution!**

**Only specialised personnel can make adjustments. Incorrect adjustment may cause malfunction of the machine's safety systems, generating a risk of serious accidents.**

### 3.2 - **ELECTRIC CIRCUIT**

The electric power used for the controls and thermal motor ignition is supplied by a 12V battery (Photo 2, page 26).

Photo 1



Photo 3



Photo 2

### 3.3 - **SAFETY SYSTEMS**

#### 3.3.1 - **Details of the main safety systems**

Automatic motor stop:

- insufficient oil pressure,
- motor oil temperature too high,
- generator or fan belt breakage.

#### 3.3.2 - **Load / overload control**

If the platform load reaches the maximum authorised load, the buzzer warns the operator.

The control circuit disables all movements. Load must be reduced to reset.

#### 3.3.3 - **Tilt control**

Photo 4



When the machine is unfolded, the tilt control detector (Photo 4, page 26) emits an audible signal as long as the slope remains greater than the maximum tilt allowed (Table 3.3.3.1, "Maximum tilt table", page 27), informing the operator that the scissors and travel movement cannot be used.

If the situation persists, after a time delay of 1-2 seconds, the scissor lifting movement command and travel command are disabled as long as the machine remains extended. To restore use of the travel movement, the whole scissor assembly must be folded.

### 3.3.3.1 - Maximum tilt table

	<i>Maximum tilt</i>
COMPACT 8DX	3°
COMPACT 10DX	3°
COMPACT 12DX	3°

### 3.3.4 - Low, Medium and High travel speed

These travel speeds are only authorised when the machine is completely folded.

When the platform is lifted, only micro-speed is possible.



## 4 - USE

### 4.1 - GENERAL INSTRUCTIONS

#### 4.1.1 - General

Your scissor-type platform is mobile.

All movements are controlled from a control box on the platform extension: this is the main operating station. The control box on the chassis is a backup or emergency station.



**Caution!**

**Do not use the machine if wind speed exceeds 45 km/h.**



**Caution!**

**Do not attempt any movements before reading and understanding the instructions in chapter 4.3.**

To avoid all risk of accident, safety systems are provided to prevent using the machine beyond its capabilities in order to protect personnel and the machine.

These systems immobilise the machine or neutralise the movements. In this case, insufficient knowledge of the machine's characteristics and operation may lead an operator to believe a breakdown has occurred whereas in fact, it is merely the safety system coming into operation.

It is therefore essential to fully understand all the instructions in the next few chapters.

#### 4.1.2 - MANUAL EXTENSIONS

The platforms are equipped with a single manual extension with several possible positions.

##### Conditions of use:

To extend or retract the extension:

- take hold of the two handles provided,
- lift them by 90°
- push them in the direction of movement required. Lifting the handles by 90° automatically releases the extension's position holding lock (Ref 1, Photo 5, page 29)

During transport on a trailer or vehicle and during work, the manual extension must be fastened and locked.

Check that the locks are properly engaged when the handles return to their initial position in order to avoid unwanted extension or retraction of the extension.

Photo 5

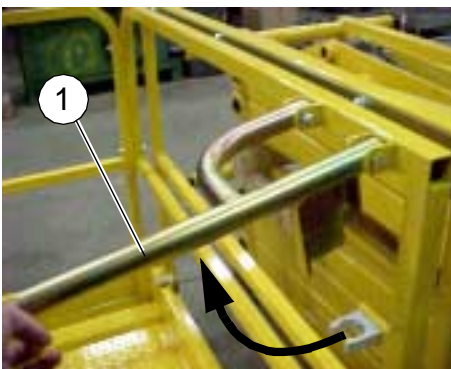

### 4.1.3 - Filling the fuel tank

(Photo 7, page 30)

Before any filling operation, ensure that the fuel is of the recommended type and that it has been properly stored to avoid contamination.

Do not draw from a barrel without decanting and never use the dregs.

Photo 6



Photo 7

To protect against the fire hazard during tank filling, the following precautions should be taken:

- do not smoke,
- stop the thermal motor if it is in operation,
- stand upwind to avoid being sprayed with fuel,
- touch the filling hole before starting to fill with the pump spout in order to avoid the risk of sparking due to static electricity,
- take care to close the tank plug properly and clean any fuel that may have spilled from the tank.

## 4.2 - LOADING, UNLOADING



### Caution!

**A false movement may cause the machine to fall and cause very serious bodily injury or material damage. Perform unloading manoeuvres on a sufficiently resistant (section § 2.6, page 15), stable, flat surface in a clear area.**

**IMPORTANT:** Before any operation, check the overall condition of the machine to make sure that it has not been damaged during transport. If necessary, make any reserves in writing to the transport company.

### 4.2.1 - Unloading by lifting

Use a lifting beam with four slings.

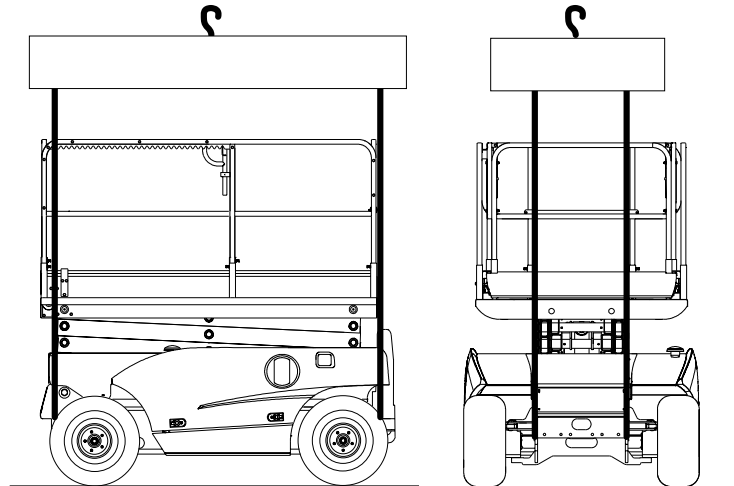

The following precautions should be taken:

- the machine is completely folded, the extension is strapped,
- the lifting accessories are in good working order and of sufficient capacity,
- the slinging accessories can bear the load and are not abnormally worn,
- the slinging lugs are clean and in good condition,
- the personnel controlling manoeuvres is authorised to use lifting equipment.

#### Unloading:

- attach the four slings to the four slinging lugs (see diagram above),
- slowly lift, ensuring that the load is evenly distributed and put the machine down again slowly.



### Caution!

**Never stand under or too close to the machine during manoeuvres.**

### 4.2.2 - Unloading with ramps

The following precautions should be taken:

- the machine is totally folded,
- the ramps can bear the load and are properly fixed,
- adhesion must be sufficient to prevent all risk of sliding during manoeuvre.

**IMPORTANT:** this method requires the machine to be started, see section § 4.3, page 33 to prevent all risk of false manoeuvre. Select low travel speed.

#### NOTE:

*The ramp slope is almost always greater than the maximum working slope (3°), causing the buzzer to sound, but travel remains possible. If the slope is greater than the maximum travel slope (see section § 2.4, page 10), use a winch as additional traction or retention means.*



**Caution!**

**Do not go down ramps at high speed.**

**4.2.3 - Loading**

The precautions are the same as for unloading.

Stowage must conform to the diagram below.

To climb the ramps of a truck, **select the low travel speed.**

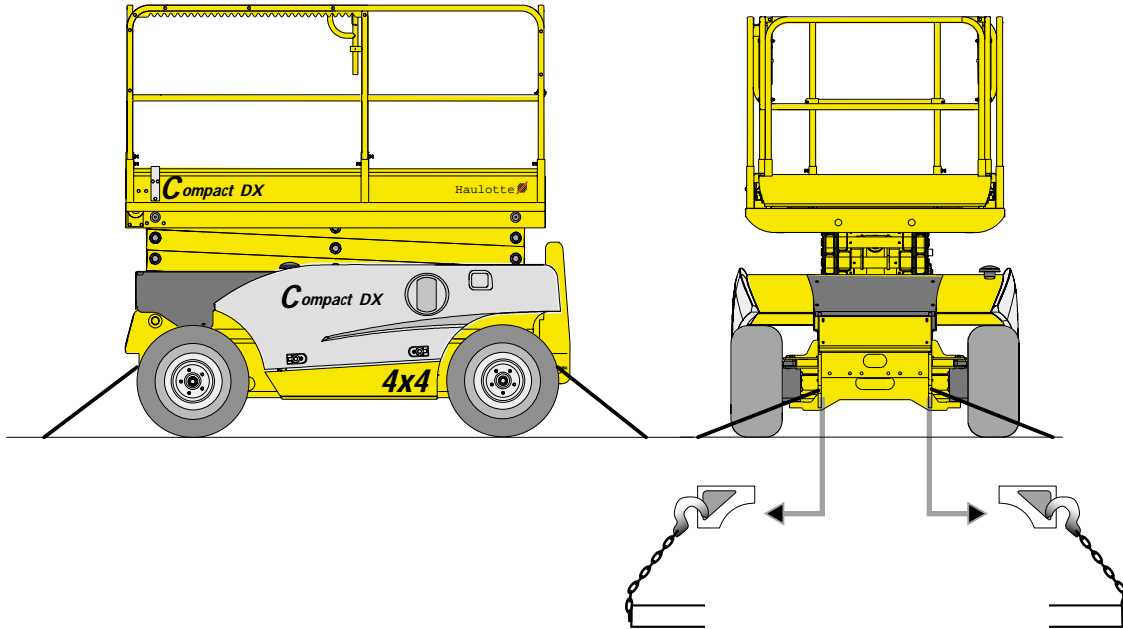

**4.2.4 - Transport instructions.**

- When transporting the machine, ensure that the vehicle capacity, loading surfaces, straps and links are sufficient to bear the weight of the machine.
- The machine should be on a level surface or fastened before the brakes are released.
- Attach the extension with straps to prevent it extending during transport.



### 4.3 - BEFORE THE FIRST OPERATION

Each platform is subjected to permanent quality checks during its manufacture.

Transport may cause damage, which must be reported to the transport company for any claim before the first operation.

REMINDER: Before any operation, learn about the machine by reading this manual and the instructions on the various plates.

#### 4.3.1 - Getting to know the control stations

All movements are controlled from a control box on the platform extension.

This is the main operating station, it must not be moved to another area on the platform or the "FORWARD" and "REVERSE" controls may be inverted.

The control box on the chassis is a backup or emergency station.

*NOTE: Do not perform any movements until you have read the instructions in section § 4.4, page 37*

You must be familiar with the machine's characteristics and operation as certain machine reactions may cause you to think a breakdown has occurred, whereas it is simply the safety systems coming into operation.

##### 4.3.1.1 - Main control station

Photo 8

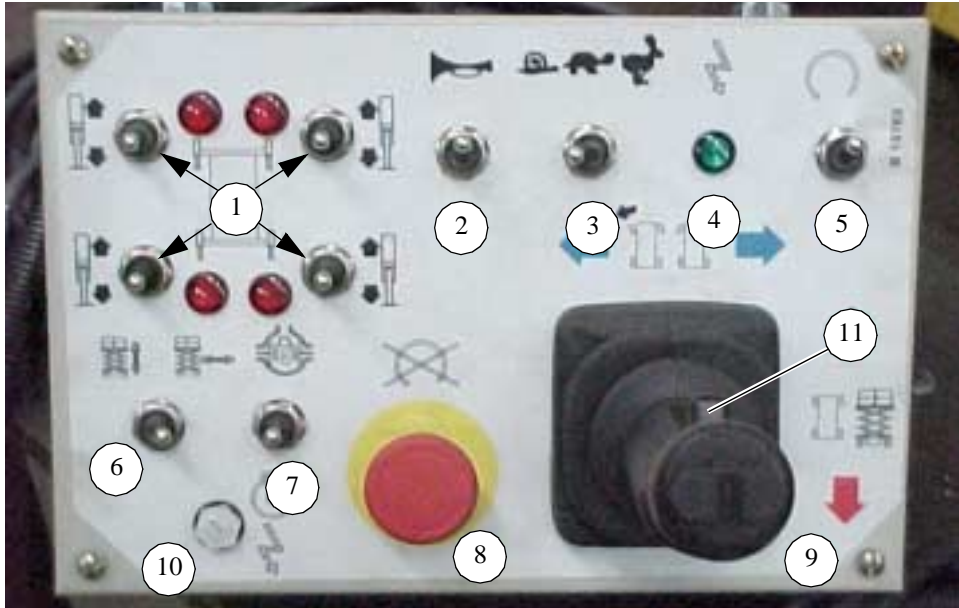

Photo 9

1- Emergency stop button	7- Oil light indicator
2- Hour counter	8- Oil pressure
3- Chassis/platform control station selection	9- Battery charge light indicator
4- Flashing light (option)	10- Air filter clogged light indicator
5- Up/down selection switch	11- Key to open the control desk
6- Thermal motor ignition	

4.3.1.2 - Platform control station

Photo 10



1- Stabiliser control + light indicator	7- Differential blocking
2- Buzzer control	8- Emergency stop button
3- Speed selection control	9- Movement control manipulator
4- Power on indicator	10- Plug
5- Thermal motor ignition	11- Fail-safe
6- Travel / up movement selection switch	

**4.3.2 - Pre-operation check**

Before operation, the machine must be visually inspected.

4.3.2.1 - Safety bar

Ensure that the safety bar (Ref.1 Photo 11, page 34) slides freely enabling access to the platform.

Photo 11



**4.3.2.2 - Overall mechanical appearance of the machine**

- Visual inspection of the whole machine: paint chips, missing or slack parts, or battery acid leaks should be noted.
- Check that there are no slack bolts, nuts, connections or hoses, no hydraulic leaks, no cut or disconnected electric conductors.
- Check the wheels: no missing or slack nuts.
- Check the tyres: not tears or wear.
- Check the lifting and steering cylinder: no sign of deterioration, oxidation or foreign matter on the rod.
- Inspect the platform and scissor arms: no visible damage, wear or deformation.
- Check the steering axle: no visible excessive wear of the pivot pins, missing or slack parts, deformation or cracks.
- Check the condition of the control box power cable.
- Check the presence of the manufacturer's plate, warning labels and operating manual.
- Check the condition of the safety barriers and access bar.

**4.3.2.3 - Machine environment**

- Check that an extinguisher in working order is available and at hand.
- Always work on hard ground, able to bear the maximum load per wheel.
- Do not use the machine at temperatures of less than  $-15^{\circ}\text{C}$ , in particular in cold rooms.
- Wipe any traces of oil or grease from the floor, ladder and handrails.
- Ensure that no-one is in the immediate proximity of the machine before lifting or lowering the platform.
- Ensure that there are no obstacles that could affect the following movements:
  - travel (machine movement).
  - platform lifting.

**NOTE:** See "working area" diagram (section § 2.4, page 10).

**4.3.2.4 - Hydraulic system**

Photo 12



Photo 13

- Check the hydraulic pump: no leaks, components properly fixed.
- Check the level of hydraulic oil (Ref 1, Photo 13, page 35).

**4.3.2.5 - Thermal motor**

- Raise the cover held by 2 tabs (Ref 1, Photo 14, page 36).

- Check the level of fuel in the tank (Ref 1, Photo 16, page 36).

Check the level of motor oil: maximum mark on the gauge (Ref 1, Photo 15, page 36).

Photo 14



Photo15

Photo 16



#### 4.3.2.6 - Safety devices

- Check that the top and bottom emergency stop buttons work properly.
- Check that the tilt detector works properly (Photo 4, page 26): activate it with the platform lifted (red emergency stop button unlocked) the buzzer should sound when the machine reaches its maximum angle.
- Check that the end of stroke contacts are free of all foreign matter.
- Check the visual and audible alarms.

 **Caution!**

**If the machine has a 220 volt current plug, the extension must be connected to a mains socket protected by a 30mA differential circuit breaker.**

## 4.4 - OPERATION

**IMPORTANT:** The machine should only be put into operation after all the checks have been completed.

### 4.4.1 - General recommendations

- Before all movement or overhead work, check that the passage is free of persons, obstacles, holes or slopes, that the slope does not exceed the maximum allowed, that the surface is hard, firm and able to bear the wheel load.
- Always drive well away from unstable edges or banks.
- Ensure that there is no-one in the immediate proximity of the machine before making any movements. Be particularly careful while the extension is out as visibility is reduced.

**REMINDER:** It is prohibited to drive on public highways.

- To move the machine, it must not be overloaded. In the case of overload, the machine is immobilised.
- Travel movement can only be controlled from the platform control station.
- It is impossible to make travel movements and lift the platform at the same time.

### 4.4.2 - Operation from the ground

(Photo 9, page 33)

#### 4.4.2.1 - Recommendations

**Danger of crushing:**

- Keep hands and limbs away from the scissors.
- Use common sense and prepare machine movement when using the bottom controls. Keep a safe distance between the machine and fixed obstacles.
- From the chassis control station, only lifting and lowering controls are available.

4.4.2.2 - Operating instructions

**Motor ignition (Photo 17, page 38):**

**NOTE:** *Hour counter: Each time the machine operates, the hours are counted, causing the "hourglass" to flash.*

Photo 17

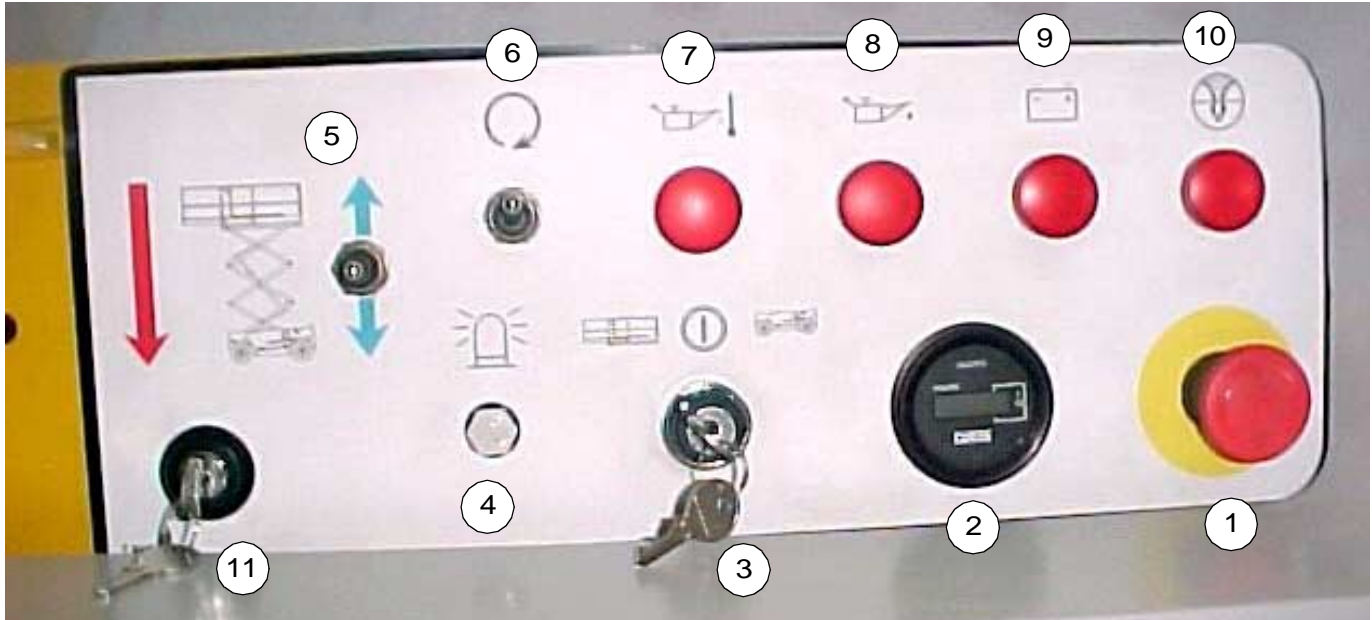

- Ensure that the stop button (Ref 1) is pulled.
- Put the control station selection key switch (Ref 3) in the "ground control" position and hold it in this position to enable other operations on this control station. In this position, the "platform" controls are cancelled.
- The motor oil pressure light indicators (Ref 8) and battery charge light indicators (Ref 2) are on. The air filter light indicator (Ref 6) is off.
- Press the ignition button (Ref 6), the motor starts, the light indicators go out.

**NOTE:** *If the motor does not start, switch off and repeat the operation. Check that the two emergency stop buttons are unlocked.*

- Allow the motor to warm up, using the time to check proper operation of the hour counter (Ref 2), motor and pump.



**Caution!**

**Do not use ignition assistance products. Leave the motor to warm up for a few minutes before loading the platform.**

**Movement test:**

Holding the ignition key (Ref 3) in the chassis position (right side), make the following movements:

- **Lift**
  - Hold the Up/down control switch (Ref 5) upwards to make this movement.
- **Lower**
  - Hold the Up/down control switch (Ref 5) downwards to make this movement.

**Motor stop:**

- Press the emergency stop button (Ref 1). When this button locks, the thermal motor is stopped and all platform controls are disabled.
- The button must be unlocked to re-enable the controls.

The motor may also stop if the chassis control desk key is put in the "platform" position instead of the "chassis" position.

**Passage to "platform" control:**

- Put the key selection switch (Ref 5) in the "platform" position.
- Check proper operation of the tilt detector. To do this, tilt the tilt detector while lifting the platform; the buzzer should sound.

**4.4.3 - Operation from the platform**



**Caution!**

**Before any operation, check that the required movement has been selected.**

**4.4.3.1 - Recommendations**

- Do not move the machine unless the safety barriers are correctly installed and the safety access bar is lowered.
- Pay attention to reduced visibility conditions and blind spots when driving and moving.
- Be careful of the correct positioning of the extended platform when moving the machine.
- We strongly recommend that operators wear approved helmets when moving the machine.
- Inspect the working area to identify overhead obstructions or other possible dangers.
- Do not perform acrobatic movements or ride a horse on the machine.
- Adapt movement speed according to the condition of the floor, traffic, slope position of people or any other factor that may cause a collision.
- Do not move the machine in the passageway of a crane or any other overhead machine unless the crane's controls have been locked and/or precautions have been taken to avoid collisions.

First, check that the on-board load is within the maximum load limits and that it is evenly distributed.

	<b>Platform</b>	<b>Extension</b>
COMPACT 8 DX PLATFORM	565 Kg - 3 occupants i.e. 325 Kg	150 Kg - 1 occupant, i.e. 70 Kg
COMPACT 10 DX PLATFORM	565 Kg - 3 occupants i.e. 325 Kg	150 Kg - 1 occupant, i.e. 70 Kg
COMPACT 12 DX PLATFORM	450 Kg - 3 occupants i.e. 210 Kg	150 Kg - 1 occupant, i.e. 70 Kg .

**NOTE:** *During platform use, the motor will be started and stopped from the platform control desk.*

Ensure that the protective bar is properly closed and that the green power light indicator is on.

Photo 18

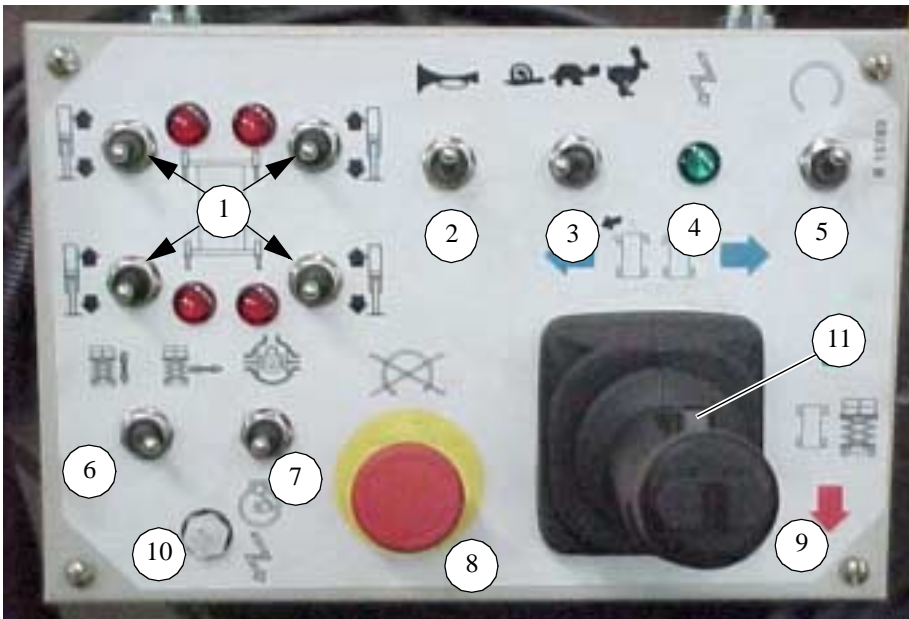

**Motor control**

Ignition: Activate the motor ignition selector switch (Ref 5).

Motor stop: push the palm button. As soon as the motor stops, release the button by turning it one quarter turn.

**Control station test**

- Before all movements, ensure that the green light indicator (Ref 4) is on, showing that machine power is on and that the selection is in the "platform" position.
- Ensure that the emergency stop button (Ref 8) is released.
- Check proper operation of the buzzer (Ref 2).

**Travel**

- Put the travel/lift selection switch (Ref 6) in the travel position.
- Select the type of speed (Ref 3).
- Check proper operation of the buzzer (Ref 2).
- Move the manipulator (Ref 9) in the direction of movement required and press the fail-safe (Ref 11).

---

*NOTE: Move the manipulator slowly: gradual manipulation = gradual movement.*

---

Do not pass through neutral without a pause. Any action on the manipulator automatically causes motor acceleration.

**Steering**

Steering is controlled by activating the buttons on the manipulator.

**Differential blocking**

Move the button (Ref 7) to the right to block the differential. Release the button to release the block (low and medium speed).

---

*NOTE: Do not cover long distances with the differential blocked. Do not steer with the differential blocked.*

---

**Lifting**

- Put the travel/lifting selection switch in the lifting position.
- Move the manipulator in the direction of movement required.



- Do not pass through neutral without a pause.

Any action on the manipulator automatically causes motor acceleration.

**REMINDER:** In the event of overload, it is impossible to lower the platform.



**Caution!**

**At the end of the lowering movement an "anti-shearing" protection system eliminates the risk of shearing when the scissors fold completely.**

Platform lowering is mainly controlled by the manipulator until a position corresponding to a minimum distance between the arms of 50 cm, thus avoiding the risk of crushing.

To continue lowering:

- Release the manipulator for four seconds, then continue the movement.
- During this period, the buzzer sounds for safety reasons.

**Stabilisers (option):** see section § 4.7, page 42

## 4.5 - BACKUP LOWERING - EMERGENCY PLATFORM OPERATION

### Backup lowering

In the event of a breakdown, put the selection key (Ref 3) on the chassis side in the chassis position, and use the backup control on the chassis control box (Ref 1).

### Emergency lowering

In the event of an electric failure on the machine, a manual emergency control next to the chassis control box enables the platform to be lowered (Ref 2).

Photo 19

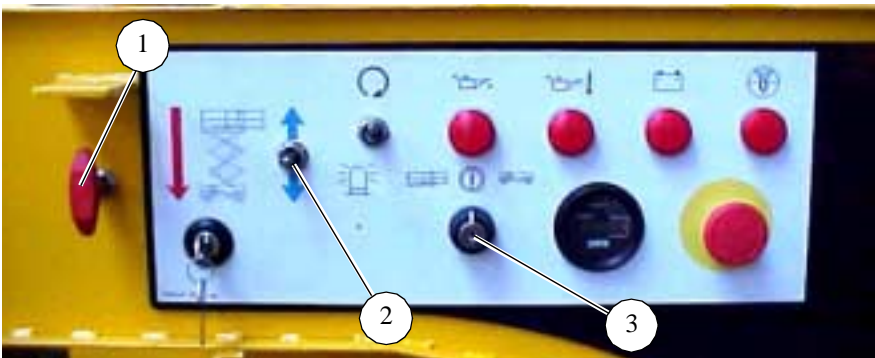

**REMINDER:** During emergency and backup operations from the ground with the extension out, it is essential to ensure that there are no obstacles under the platform (wall, cross rail, electric line, etc.).



**Caution!**

**It is forbidden to lower overloads using the emergency lowering operation.**

## 4.6 - BRAKE RELEASE

The brakes are released manually. (Photo 20, page: 42)

### Operating instructions:

- Close valve N1 (Ref 2).

- Activate the hand pump until the brakes are fully released (Ref 1).
- Open valve N2 (Ref 3).
- Tow the machine at low speed.
- Once in position:
  - Close valve N2 (Ref 3).
  - Open valve N1 (Ref 2).

Photo 20

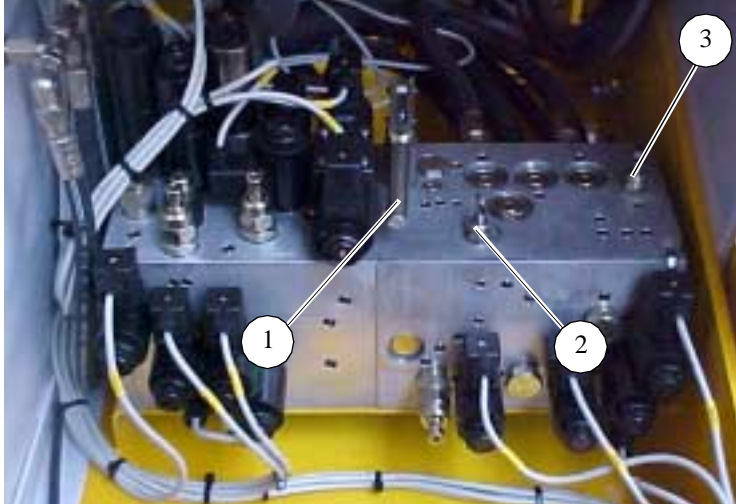

#### **4.7 - STABILISERS**

A set of four cylinders fixed to the chassis, controlled from the platform control desk, enable machine stability to be increased.

The four switches (Ref.1, Photo 18, page 40) control extension and retraction of the stabiliser cylinders. One, two, three or four cylinders can be controlled at the same time for a same movement (lifting or lowering).

The first movement selected takes priority.



**Caution!**

***The stabilisers must always be adjusted with the platform horizontal in the bottom position. The four cylinders must be in position on the ground. Never alter stabiliser position once the machine is extended.***

**SERIOUS RISK OF OVERTURNING**

**Stabiliser extension:**

- Move the stabiliser buttons (Ref 1, Photo 18, page 40) downwards. Moving the four buttons at the same time means slower lowering of the stabilisers.
- During cylinder extension, the buzzer sounds and the corresponding light indicator on the platform control desk comes on.

**Stabiliser retraction:**

- Move the stabiliser buttons (Ref 1, Photo 18, page 40) upwards. Moving the four buttons at the same time means slower rising of the stabilisers.

---

**NOTE:** *The stabiliser extension and retraction occurs without acceleration.*

---

**Caution!**

***Travel is disabled if at least one stabiliser is extended.***

**Ground detection:**

- The ground is detected by four pressure contacts.
- The four light indicators flash until the cylinders are positioned on the ground and if the manipulator is pushed.
- The lifting movement is authorised if the machine is stabilised or if the four cylinders are extended.

**The machine is equipped with 3 safety systems:**

- The travel functions are disabled as long as the four cylinders are not fully retracted.
- Cylinder position can only be adjusted when the platform is lowered.
- When the cylinder is extended, the corresponding light indicator is on.
- The "lifting" function is only possible if the four cylinders are in contact with the ground or all retracted.



## 5 - MAINTENANCE

### 5.1 - GENERAL RECOMMENDATIONS

The servicing operations described in this manual are given for normal operating conditions.

**In difficult conditions:** extreme temperatures, high humidity, polluted atmosphere, high altitude, etc. certain operations should be performed more often and specific precautions taken: consult PINGUELY HAULOTTE's After-Sales department for such cases.

Only approved and skilled personnel may intervene on the machine and must respect the safety instructions concerning Personnel and Environment protection.

For the motor part, consult the manufacturer's manual.

Regularly check that safety systems work properly:

- Tilt: buzzer + stop (travel and lifting disabled).
- Platform overload - load > 200 kg, buzzer + total stoppage of all movements (lowering and travel disabled).



**Caution!**

**Do not use the machine as a welding earth.**

**Do not weld without disconnecting the (+) and (-) terminals of the batteries.**

**Do not start other vehicles with the batteries connected.**

### 5.2 - MAINTENANCE SYSTEM

Photo 21



#### Operating instructions:

These operations are to be carried out on both sides of the platform.

#### Positioning of the maintenance stands:

- Park the lifting platform on firm, horizontal ground.
- Ensure that the two emergency stop buttons are "ON".
- Turn the ignition key on the chassis control desk to "chassis" (Ref 3, Photo 17, page 38).
- Move the chassis control desk lifting switch upwards to lift the platform (Ref 5, Photo 17, page 38).
- Unscrew, turn the maintenance stand and allow it to hang vertically (Photo 21, page 45).
- Push the lifting switch (Ref 5, Photo 17, page 38) to the bottom position to gradually lower the platform until the maintenance stand is in contact with the two fixing points (top and bottom).

**Removing the maintenance stand:**







- Push the chassis lifting switch up and gradually lift the platform until the maintenance stand is free (Ref 5, Photo 17, page 38).
- Turn the maintenance stand until it is in contact in its storage position and screw back into place (Photo 21, page 45).
- Push the chassis control desk lifting switch down and lower the platform completely (Ref 5, Photo 17, page 38).

**5.3 - MAINTENANCE PLAN**

The maintenance plan shows the frequency, maintenance points (device) and ingredients to be used.

- The reference shown in the symbol shows the maintenance point according to the frequency.
- The symbol represents the consumable to be used (or the operation to be carried out).

**5.3.1 - Consumables**

INGREDIENT	SPECIFICATION	Symbol	Lubrificiers used by PINGUELY - HAULOTTE	ELF	TOTAL
Motor oil	SAE 15W40		SHELL RIMULA-X		
Hydraulic oil	AFNOR 48602 ISO VG 46		BP SHF ZS 46	HYDRELF DS 46	EQUIVIS ZS 46
Extreme pressure lithium grease	ISO - XM - 2				
Lead-free grease	Grade 2 ou 3		ESSO GP GREASE	MULTIMOTIVE 2	MULTIS EP 2
Exchange or specific operations					
Lithium grease	ENS / EP 700				

### 5.3.2 - Maintenance diagram

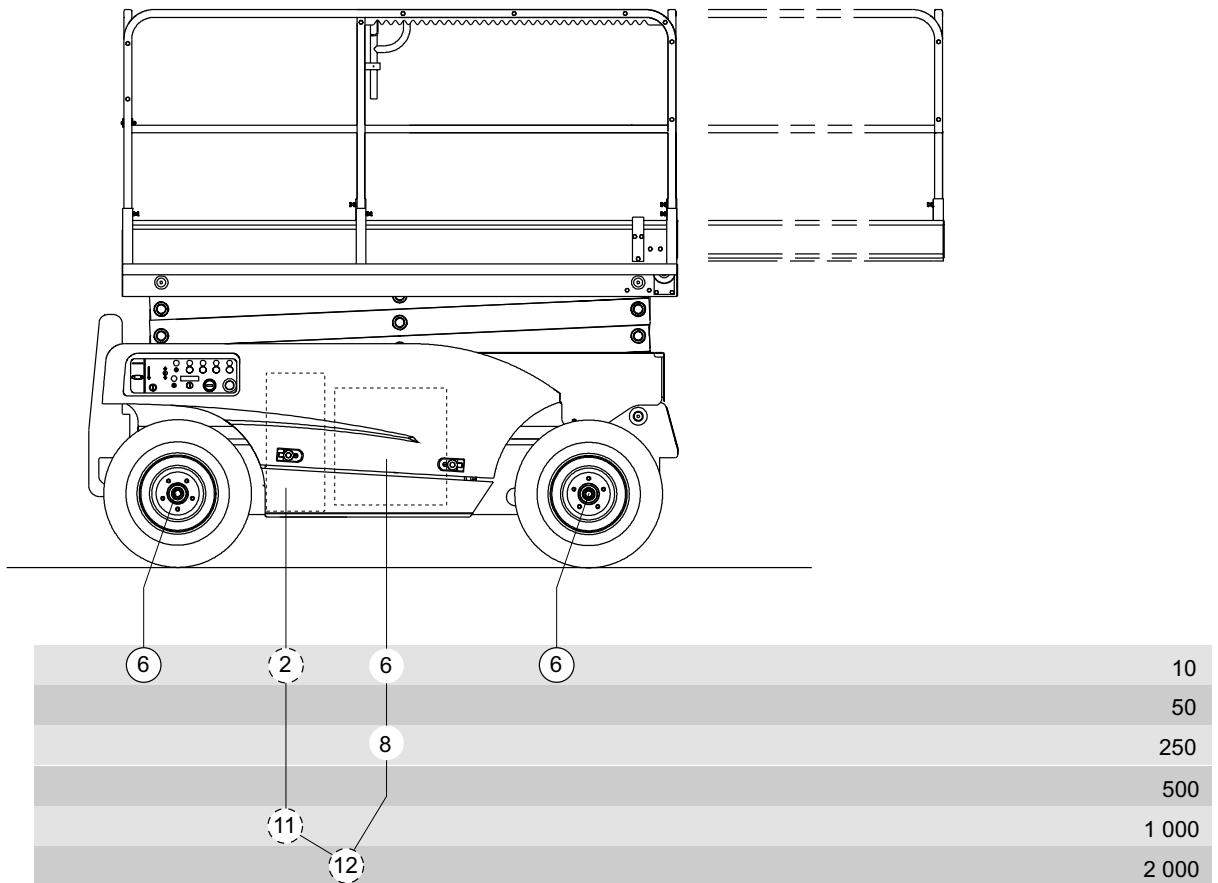
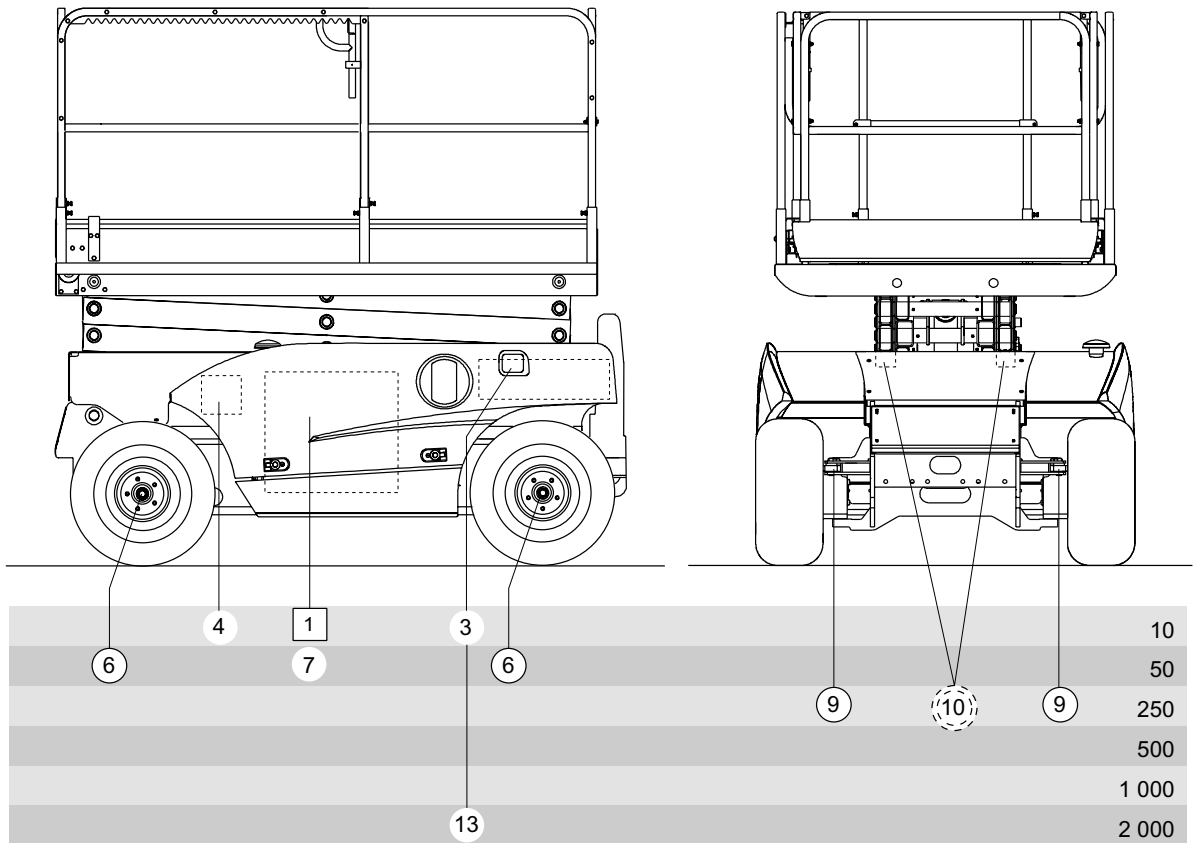

**5.4 - OPERATIONS**

**5.4.1 - Summary table**

<i>FREQUENCY</i>	<i>OPERATIONS</i>	<i>Ref</i>
Every day or before each start of operation	<ul style="list-style-type: none"> <li>• Check levels:                             <ul style="list-style-type: none"> <li>- motor oil,</li> <li>- hydraulic oil,</li> <li>- diesel,</li> <li>- electric batteries,</li> </ul> </li> <li>• Check cleanliness:                             <ul style="list-style-type: none"> <li>- diesel pre-filter, replace if water or impurities are found,</li> <li>- machine (in particular, check the tightness of connections and hoses), also check tyre condition, cables and all other accessories and equipment.</li> </ul> </li> </ul>	<p>1</p> <p>2</p> <p>3</p> <p>4</p>
Every 50 hours	<ul style="list-style-type: none"> <li>• Grease:                             <ul style="list-style-type: none"> <li>- wheel pivot pin axles: 2 x 2 points.</li> </ul> </li> <li>• Check diesel pre-filter, replace if water or impurities are found.</li> </ul> <p>CAUTION: after the first 50 hours:</p> <ul style="list-style-type: none"> <li>• Change the hydraulic filter cartridge (see 250 hour frequency).</li> <li>• Check the tightness:                             <ul style="list-style-type: none"> <li>- of screws, nuts and bolts in general,</li> <li>- of wheel nuts (torque 25 daNm).</li> </ul> </li> </ul>	<p>6</p> <p>7</p>
Every 250 hours	<p>Motor: see Manufacturer's manual.</p> <ul style="list-style-type: none"> <li>• Change the hydraulic filter cartridge.</li> <li>• Grease:                             <ul style="list-style-type: none"> <li>- the steering wheel pivot pints</li> <li>- the friction parts of the slides (spatula)</li> <li>- the battery terminals</li> </ul> </li> </ul>	<p>8</p> <p>9</p> <p>10</p>
Every 500 hours	<p>Motor: see Manufacturer's manual.</p> <ul style="list-style-type: none"> <li>• Fill up: capacity 2 x 0.7 l for 4x2 - 4 x 0.7 l for 4x4.</li> </ul>	
Every 1000 hours or every year	<p>Motor: see Manufacturer's manual.</p> <ul style="list-style-type: none"> <li>• Oil change: hydraulic oil tank</li> </ul>	11
Every 2000 hours	<p>Motor: see Manufacturer's manual.</p> <ul style="list-style-type: none"> <li>• Oil change: hydraulic tank and whole oil circuit.</li> <li>• Empty and clean diesel tank.</li> </ul>	12 13
Every 3000 hours or every 4 years	<ul style="list-style-type: none"> <li>• Check:                             <ul style="list-style-type: none"> <li>- the condition of the slides,</li> <li>- the condition of the electric cables and hydraulic hoses etc.</li> </ul> </li> </ul>	

REMINDER: All these frequencies should be reduced in the case of work in difficult conditions (consult the After-Sales department if necessary).



## 5.4.2 - Operating instructions

### IMPORTANT:

Only use the lubricifiers recommended in the table in section § 5.3, page 46 for filling up and greasing operations.

Collect emptied oil to avoid environment contamination.



### Caution!

**Check that the machine is stabilised, and that the lifting means are of sufficient capacity and in good condition.**

### 5.4.2.1 - Greasing the steering wheel pivot pins

Photo 22

Grease the pivot pins (Ref.1) with lead-free grease.

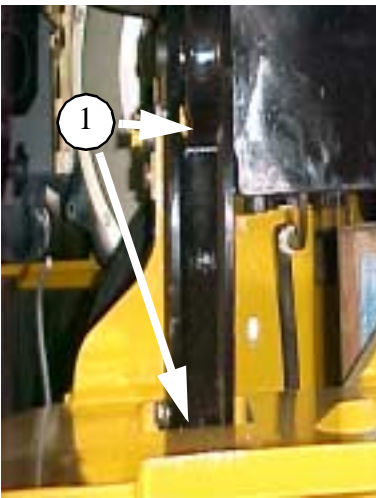

### 5.4.2.2 - Greasing the slides

(Photo 23, page 49)

Photo 23

Grease with lithium grease using a spatula.



## 5.4.3 - List of consumables

- Hydraulic filter cartridge
- Air filter element
- Diesel pre-filter
- Diesel filter
- Motor oil filter



## 6 - OPERATING INCIDENTS

The next few pages will give you a starting point for solving any problems that may occur during scissor platform operation.

If a problem arises that is not mentioned in this section or if it is not solved by the solutions proposed, consult qualified technical personnel before performing any maintenance operations. Most problems encountered on this machine occur mainly in the hydraulic and electric systems.

Before anything else, check that:

- The two emergency stop buttons on the chassis control box and on the platform control box are unlocked and the key is in the chassis or platform position.

### 6.1 - PLATFORM LIFTING SYSTEM

<i>ANOMALY</i>	<i>CHECK</i>	<i>PROBABLE CAUSE</i>	<i>SOLUTION</i>
No movement when the lifting switch on the box and the manipulator are activated.	Check that movement occurs when the lifting switch on the on the chassis control box is activated.	Control switch does not work.	Replace the switch (After-Sales department).
		Manipulator does not work.	Replace the manipulator (After-Sales department).
		Insufficient oil in the hydraulic circuit.	Fill up with oil as necessary.
The platform does not go up.		Load on the platform too heavy (personnel or material)	Reduce load.
		Insufficient oil in the hydraulic circuit.	Fill up with oil as necessary.
		Tilt	Check the position of the machine and ensure that it is not tilted.
The platform does not go down.		Load on the platform too heavy (personnel or material).	Reduce load.
The platform moves up and down with a jolty movement.		Insufficient oil in the hydraulic circuit.	Fill up with oil as necessary.

**6.2 - TRAVEL SYSTEM**

<b>ANOMALY</b>	<b>CHECK</b>	<b>PROBABLE CAUSE</b>	<b>SOLUTION</b>
No movement when the switch is in the travel position and the manipulator on the platform control box is activated.		The manipulator does not work.	Repair or replace the manipulator (After-Sales department).
		Insufficient oil in the hydraulic circuit.	Fill up with oil as necessary.
		Tilt	Check the position of the machine and ensure that it is not tilted.
		Overload.	Reduce load.
The machine goes into runaway during lowering.		Balancing valve incorrectly adjusted or not working properly.	Adjust or replace the balancing valve (After-Sales department).

**6.3 - STEERING SYSTEM**

<b>ANOMALY</b>	<b>CHECK</b>	<b>PROBABLE CAUSE</b>	<b>SOLUTION</b>
No movement when the manipulator is activated.		Insufficient oil in the hydraulic circuit.	Fill up with oil as necessary.
		The control manipulator does not work.	Replace the manipulator (After-Sales department).
Noisy hydraulic pump.		Insufficient oil in the tank.	Fill up with oil as necessary.
Hydraulic pump cavitation (vacuum in the pump due to insufficient oil).*	The hydraulic oil becomes cloudy, opaque and white (bubbles observed).	Oil viscosity too high.	Empty the circuit and fill with the recommended oil.
Hydraulic circuit overheating.		Oil viscosity too high.	Empty the circuit and fill with the recommended oil.
		Insufficient hydraulic oil in the tank.	Fill up with oil as necessary.
The system works irregularly.		The hydraulic oil is not at optimal operating temperature.	Make a few movements without load to allow the oil to heat up.

**\*CAUTION:**

- **CAVITATION = BUBBLES**
- **BUBBLES + PRESSURE = SERIOUS PROBLEM (OLEOPNEUMATIC SYSTEM)**
- **BUBBLES + PRESSURE + HEAT = DANGEROUS SITUATION.**

**NOTE:** *It takes approximately 4 hours for the oil emulsified under the effects of cavitation to return to its normal appearance.*

## 7 - SAFETY SYSTEM

### 7.1 - CHASSIS BOX RELAY AND FUSE FUNCTION

(see wiring diagram)

KA2	Thermal motor ignition.	FU5-3 A	Circuit fuse on movement control from chassis.
KP1	Thermal motor stoppage.	FU6-3 A	Circuit fuse on movement control from platform.
KT2	Movement acceleration (electro-motor).	FU7-20 A	Electrovalve supply circuit fuse.
KMG	Mains power.	FU8-5 A	Control circuit fuse.
FU3-80 A	Accelerator circuit fuse.	FU9-20 A	Accessory circuit fuse.
FU4-30 A	Mains circuit fuse (motor).	FU10-3 A	Circuit fuse.

### 7.2 - SAFETY CONTACT FUNCTION

(see wiring diagram)

SB1	Emergency stop push button.	SQ10	Rear right stabiliser.
SB2	Emergency stop push button.	SQ12	12 meter travel disable
SQ1	Tilt box. Disables platform lifting and travel.	B2	Motor oil temperature.
SQ3	Tilt reset, if machine folded.	B1	Air filter contact. Light indicator on if air filter clogged.
SQ4	Top end of travel sensor.	B3	Oil pressure contact. Motor cut off if insufficient pressure.
SQ7	Front left stabiliser.	B4	Hydraulic oil temperature contact. Audible alert if temperature too high.
SQ8	Front right stabiliser.	B6	Overload. Audible alert if overloaded.
SQ9	Rear left stabiliser.	B7 to B10	Machine stabilised detection.



---

## **8 - HYDRAULIC DIAGRAMS**

---

8.1 - COMPACT 8, 10 DX

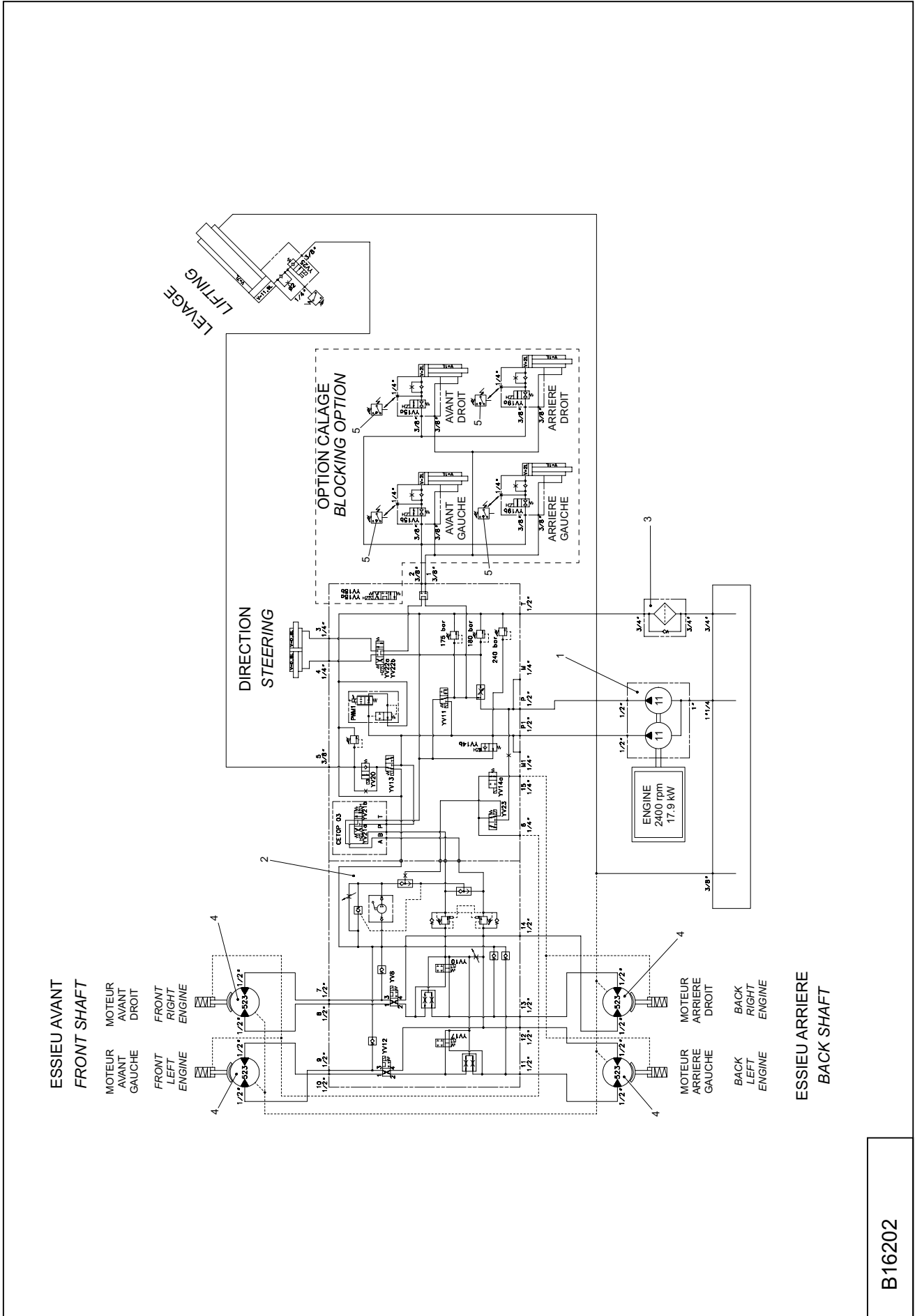

B16202



8.2 - COMPACT 12 DX

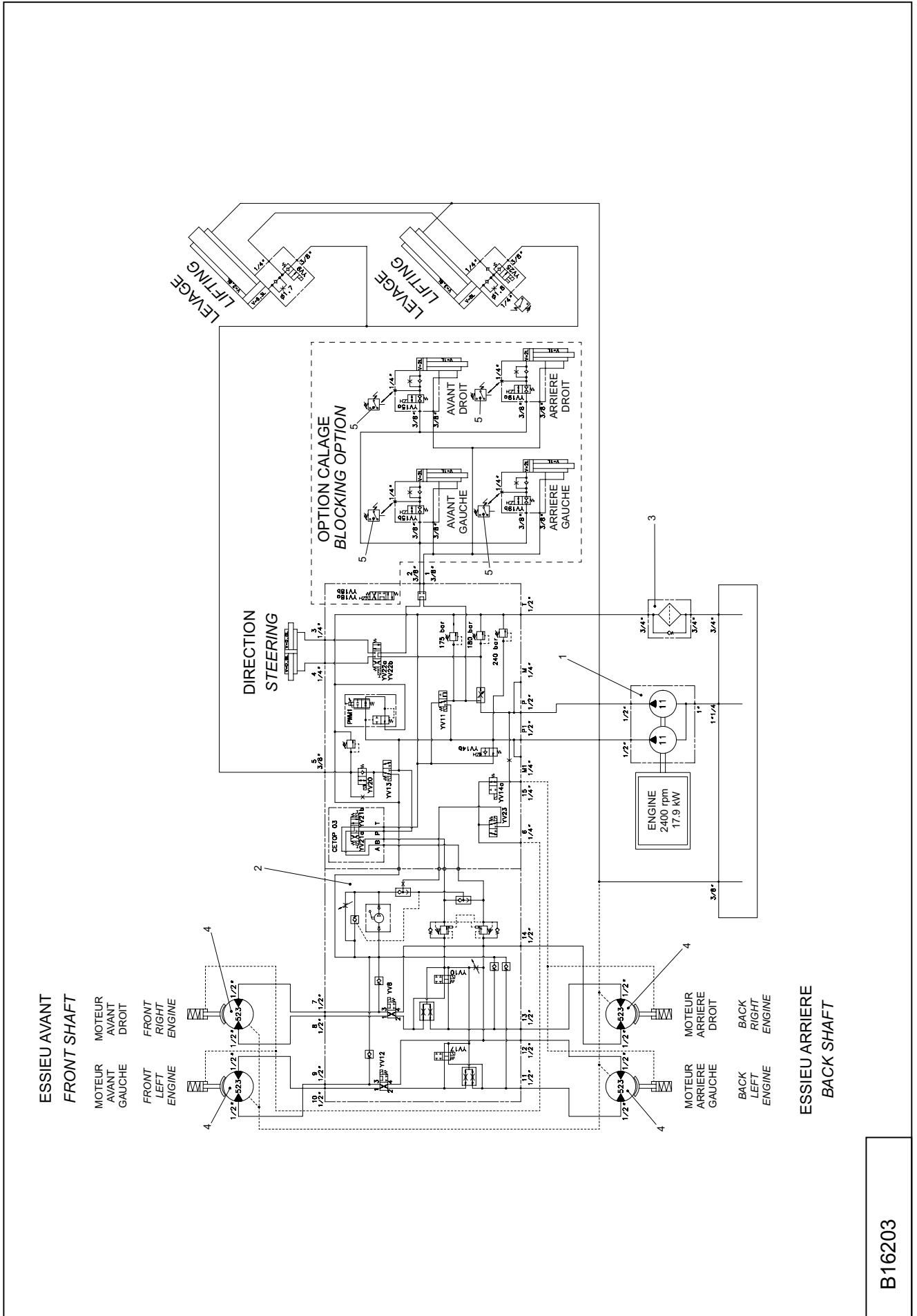

B16203



# 9 - WIRING DIAGRAM

## 9.1 - COMPACT 8, 10, 12 DX

